

การออกแบบและสร้างเครื่องกระตุ้นไฟฟ้าแบบกระแสไดโอดนามิก

THE DESIGN AND CONSTRUCTION OF DIADYNAMIC CURRENT STIMULATOR

ธีระ ลีอุดมวงษ์, วีระศักดิ์ อัสววงค์อารยะ และบุษปภัทร นาดวงษ์

Theera Leeudomwong, Weerasak Ussawawongaraya and Budsapat Natwong.

Department of Industrial physics and Medical Instrumentation, Faculty of Science, King Mongkut's Institute of Technology North Bangkok, Bangkok 10800, Thailand; e-mail address: trl@kmitnb.ac.th

บทคัดย่อ: กระแสไฟฟ้าหลากหลายรูปแบบถูกนำมาใช้ในการกระตุ้นกล้ามเนื้อหรือเส้นประสาทเพื่อให้เกิดผลทางด้านกายภาพบำบัด ไดโอดนามิกเป็นกระแสไฟฟ้ารูปแบบหนึ่งที่ทำให้ผลบำบัดรักษา เช่น ระวังอาการปวด ลดการเกร็งของกล้ามเนื้อ และเพิ่มการไหลเวียนเลือด ไมโครคอนโทรลเลอร์ถูกนำมาประยุกต์ใช้ร่วมกับวงจรอิเล็กทรอนิกส์เพื่อกำเนิดกระแสไฟฟ้าแบบไดโอดนามิก 5 ชนิด ได้แก่ MF, DF, CP, CPid และ LP โดยปริมาณกระแสไฟฟ้าสามารถปรับตั้งได้ 0 – 80 มิลลิแอมแปร์และระยะเวลาในการรักษาสสามารถปรับตั้งได้ 0 – 15 นาที การทดสอบด้านการกำเนิดสัญญาณและปริมาณกระแสไฟฟ้าได้ทำโดยการใช้ตัวต้านทานที่ทราบค่าทำหน้าที่แทนเนื้อเยื่อในบริเวณที่จะทำการรักษา ขนาดและรูปร่างของสัญญาณแต่ละชนิดสามารถวัดและแสดงผลได้จากการใช้ออสซิลโลสโคปและอาศัยกฎของโอห์มคำนวณปริมาณความเข้มของกระแสไฟฟ้าที่เครื่องกำเนิดขึ้น พบว่าเครื่องกระตุ้นไฟฟ้าแบบกระแสไดโอดนามิกที่ได้ออกแบบและสร้างขึ้นสามารถกำเนิดกระแสไฟฟ้าในรูปแบบที่กำหนดได้อย่างถูกต้อง สามารถให้ปริมาณความเข้มของกระแสไฟฟ้าให้กับเนื้อเยื่อตรงกับปริมาณที่ต้องการ และสามารถควบคุมปริมาณกระแสไฟฟ้าให้คงที่ได้เมื่อความต้านทานของเนื้อเยื่อเปลี่ยนแปลงไป ซึ่งแสดงให้เห็นว่าเครื่องกระตุ้นไฟฟ้าแบบกระแสไดโอดนามิกที่สร้างขึ้นสามารถนำไปใช้ประโยชน์ให้เกิดผลทางกายภาพบำบัดได้เป็นอย่างดี

Abstract: There are many kinds of electrical current utilized to stimulate nerve and muscle for physical therapeutic purposes. One of those is a diadynamic current that effects to relieve pain, relax muscle and increase blood circulation. A microcontroller and specific electronic circuits were applied to generate five forms of the diadynamic current – MF, DF, CP, CPid and LP. The current intensity ranged from 0 to 80 mA and the treatment time was adjusted from 0 to 15 minutes. Instead of placing a known value resistor on the patient's nerve and muscle treatment region, it was connected to the output port of the micro controller. The generated current waveform and intensity across the resistor were then measured and displayed on oscilloscope. The amount of current intensity was calculated using Ohm's law. The experiment showed that this constructed electrical stimulator correctly produced all desired waveforms of diadynamic current, accurately released the stimulating current at desired level and constantly maintained the current intensity when the tissue resistance was changed. For this reasons, the constructed diadynamic current stimulator can be practically used for therapeutic purposes.

Introduction : Electrical currents have been used for therapeutic purposes for hundreds of years. With the development of different forms of electrical generators during this century, the types of electrical currents employed in the therapeutic applications have proliferated. One of those is the diadynamic currents introduced by France dentist, Pierre Bernard. There are two basic forms that are DF and MF. DF(diphase fixe) known as full-wave rectified sinusoidal current is a continuous series of 10 ms sinusoidal pulses resulting in a frequency of 100 Hz. MF (monophase fixe) consists of a series of 10 ms half sine wave-shaped pulse with 10 ms pulse intervals resulting in a frequency of 50 Hz. If these two current forms – MF and DF – are applied alternately for 1 second each the resulting current is called CP module (module en courtes periodes). CPid module is similar to CP module but the amplitude is increased by approximately 10 % during DF phase. If two MF currents are applied so that one series of pulses occupies the pulse intervals of the other and one is of constant intensity while the other is surged, the result is called LP module (module en longues periodes). The length of each surge and surge interval is usually 5 or 6 seconds. All mentioned forms of diadynamic currents is shown in figure 1.

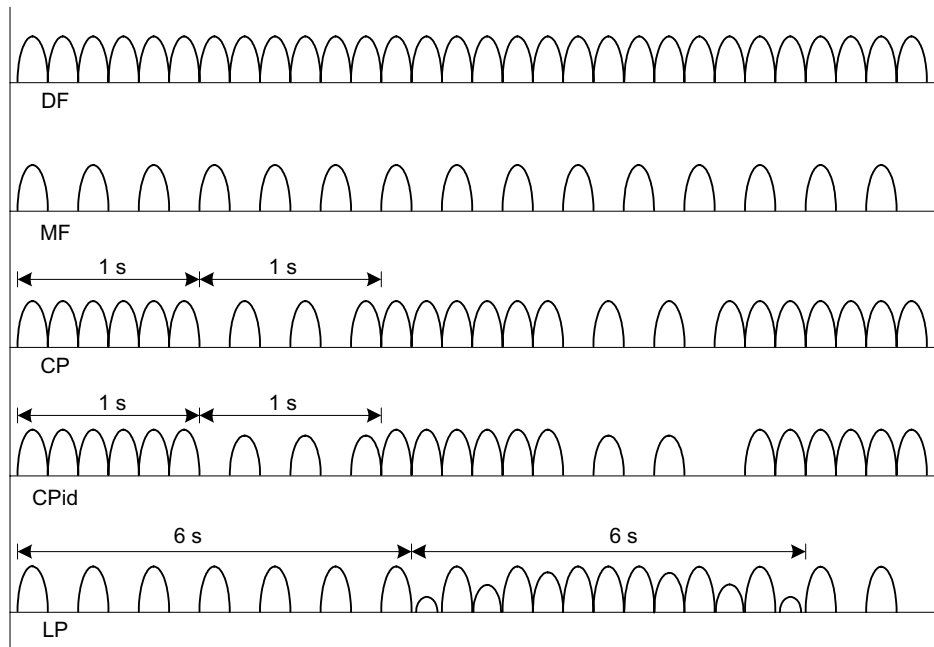

Figure 1. Diadyamic Current Waveforms

This study introduces the design and construction of the diadyamic current stimulator for utilizing in physical therapy. Five forms of diadyamic currents can be produced: DF, MF, CP, CPid and LP. The current intensity can be controlled from 0 to 80 mA and the treatment time can be adjusted from 0 to 15 minutes.

Methodology: The design and construction of the diadyamic current stimulator are based on the block diagram in figure 2. All operations take place under the control of the central processing unit(CPU), the 89C52 microcontroller. The desired current waveforms and intensity are easily selected by turning the current selector and intensity control knob respectively. Both information need to be converted from analog to digital form for processing by the microcontroller, therefore the ADC0832, a 8-bit successive approximation analog to digital converter(ADC) with a serial input/output and configurable input multiplexer with 2 channels, has been used. Besides the treatment times and polarity can be set by pressing the input switches connected to the input/output ports of the microcontroller. By using the MAX7219, a compact, serial input/output common cathode display driver that interfaces microcontroller to 7-segment numeric LED display, the adjusted treatment time and current are visibly showed. After the microcontroller collects and processes all acquired data, it send out the series of data corresponding to the selected waveform of diadyamic current to the digital to analog converter(DAC), AD7524. The DAC output voltage is connected to the input of the output stage and its amplitude is determined by the reference voltage derived from the adjustment of the current intensity. The output state is a current source circuit. The output current is the current passing through the patient's muscle and nerve, also called patient current. It is constantly controlled by the amplitude of input voltage obtained from the DAC output. The polarity relays are designed to cooperate with the output stage to define the stimulating polarity. For testing, a known value resistor is connected to the output instead of the patient's muscle and nerve. The amplitude and waveform are measured by using the oscilloscope. The output current is calculated by Ohm's Law and compared with the theoretical output current from the design.

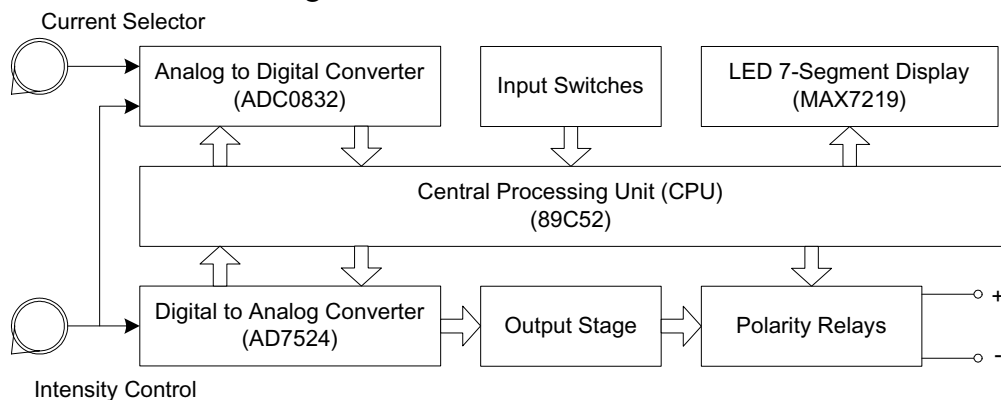

Figure 2. Diagram of diadyamic current stimulator.

Result, Discussion and Conclusion

The diadynamic waveforms from the constructed electrical stimulator are measured and showed in figure 3. Only four types of current can be properly recorded and displayed on screen of the oscilloscope.

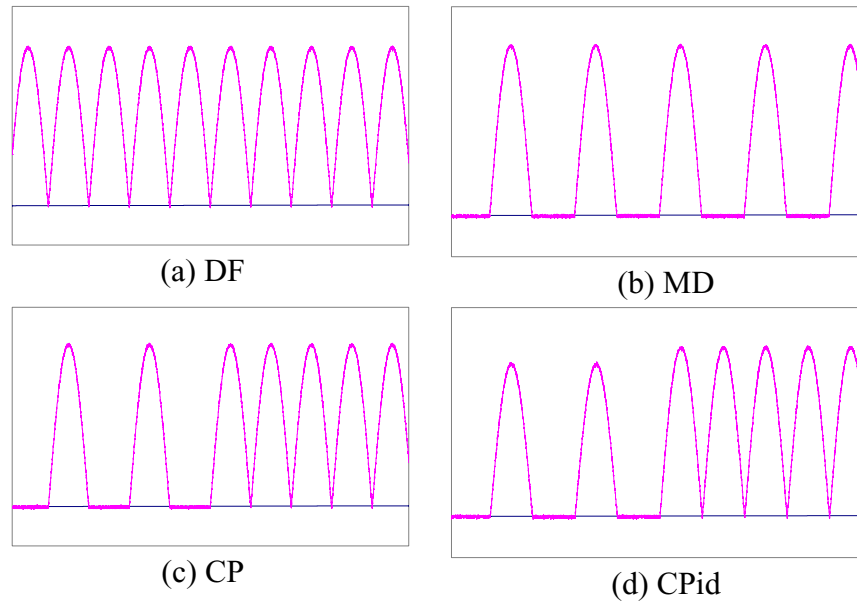

Figure 3. Diadynamic current waveforms recorded from the constructed stimulator.

The information from the experiment showed that the constructed electrical stimulator can properly generate all kinds of diadynamic waveforms with the acceptability of desired output current. Moreover, the produced output currents are also able to adapt with the change of the resistance. Therefore, the electrical current passing the patient's muscle and nerve will be able to vary with the resistance of tissue as well. For this reasons, this constructed stimulator could be properly applied for utilization in the therapeutic purposes. In the therapeutic applications, the electrodes are used to conduct the electrical current from the stimulator to patient. A problem was met during the use. The poor contact sometimes occurs between the electrode-skin interfaces. The performance of this constructed stimulator would be better if it will be developed to be detectable the electrode-skin interface.

References: (1) John Low, Ann Reed, *Electrotherapy Explained: Principles and practice*, Butterworth-Heinemann Ltd. , Second edition 1994.

(2) Andrew J. Robinson, Lynn Snyder-Mackler, *Clinical Electrophysiology: Electrotherapy and Electrophysiologic Testing*, Williams & Wilkins, 1995.

(3) Enraf-Nonius BV, *Diadynamics*, Delft-Holland 1985. 1-45.

(4) David A. Bell, *Operational Amplifiers: Applications, Troubleshooting, and Designs*, Prentice Hall, Internation, Inc. 1990.

Keywords: diadynamic current stimulator.