

ASSOCIATIONS OF COMMON β -THALASSEMIA MUTATIONS WITH β -GLOBIN GENE FRAMEWORKS IN NORTHERN THAILAND

P. Sanguansermisri, D. Shimbhu, R. Wongvilairat

Faculty of Medical Science, Naresuan University, Phitsanulok 65000, Thailand

T. Sanguansermisri*

Faculty of Medicine, Chiang Mai University, Chiang Mai 50200, Thailand

Received 1 May 2003, Accepted 17 September 2003

ABSTRACT

This study aimed to characterize polymorphism of the β -globin gene (framework) among common β -thalassemia mutations found in northern Thailand. Thirty-one homozygous β -thalassemia major patients admitted to Chiang Mai University Hospital were identified using direct DNA sequencing method. Among 15 patients with homozygous of codon 41/42 (-TCTT), eight were homozygous of framework 1 (FW1), one was homozygous of FW3A, and the remainders were heterozygous of FW1 and FW3A. The gene frequencies of FW1 and FW3A in the patients were 0.733 (22/30) and 0.267 (8/30), respectively. All 11 patients with homozygous of codon 17 (A-T) were homozygous of FW3A, while three patients with homozygous of intron 1 nt 1 (G-T) were homozygous of FW1. Both patients with homozygous of codon 71/72 (+A) were FW3A. In this report, the numbers of β -globin gene frameworks were restricted in each β -thalassemia mutation. This investigation may provide further information for the study of the evolution of common mutations causing β -thalassemia major in northern Thailand.

1. INTRODUCTION

β -thalassemia is a group of single gene defect characterized by reduced or absent synthesis of the β -globin chain of hemoglobin⁽¹⁾. In Thailand, the prevalence of carriers is 3-9%⁽²⁾. The majority of β -thalassemias is caused by point mutations or small insertion or deletion within the β -globin gene or their surrounding sequences. Almost 200 β -thalassemia alleles have currently been characterized. However, in certain ethnic group, most of the cases are limited in the subset of mutations⁽³⁾. The common mutations of patients admitted to Chiang Mai University Hospital are codon 41/42 (-TCTT), codon 17 (A-T), intron I nt 1 (G-T), and codon 71/72 (+A). The most frequent genotype was compound heterozygous of codon 17 (A-T) and codon 41/42 (-TCTT) which is about 33% whereas the homozygous of codon 41/42 (-TCTT) and homozygous of codon 17 (A-T) are about 24% and 11%, respectively⁽⁴⁾.

In normal population, micro-haplotypes of β -globin gene called framework (FW) are defined by five silence mutations at codon 2 nt 3 (C-T) and intron II nt 16 (C-G), nt 74 (G-T), nt 81 (C-T) and nt 666 (T-C). From the FW1, which is the wild type, FW2 has one point mutation at nt 74, FW3 have all five mutations, and FW3A have four mutations but nt 81^(5,6). Several sources of information about framework came from deduction of 3'-subhaplotype of RFLP-haplotype of β -globin genes cluster by using two restriction sites of *Hgi* A I at codon 2 nt 3 or *Ava* II at intron II nt 16 of β -globin gene and *Bam* H I site at its 3' end. The results of ++, +-, and -+ were assigned to FW1, FW2 and FW3 respectively⁽⁶⁻⁹⁾. However, there may be discrepancy with direct DNA sequencing method due to effect of gene conversion⁽¹⁰⁾.

In this report, the data were collected using direct DNA sequencing of PCR product from homozygous patients instead of more common compound heterozygous of codon 17 (A-T) with codon 41/42 (-TCTT) to avoid any base errors of cloning from PCR product which may be caused from fidelity of *Taq* polymerase⁽¹¹⁾. Currently, there have been no report about framework from the data of homozygous of codon 17 (A-T) and codon 41/42 (-TCTT) using direct DNA sequencing in Thailand.

2. EXPERIMENTAL PROCEDURE

2.1 Sample preparation

From β -thalassemia major patients admitted at Chiang Mai University Hospital whom were known the type of their mutations, 15 homozygous of codon 41/42 (-TCTT), 11 homozygous of homozygous of codon 17 (A-T), three of homozygous of intron I nt 1 (G-T), and two of homozygous of codon 71/72 (+A) patients were included in the studies. The DNA was extracted using a modified version of Chelex-100 extraction method⁽¹²⁾.

2.2 Sample characterization

To determine the framework, amplicons to identify the codon 2 nt 3 were created using primers and PCR condition that has been previously reported⁽¹³⁾. The rest of the sequence were ascertained by a set of primers BIVS2S1 (5'- tca cct gga caa cct caa g-3') and BIVS2A2 (5'-taa tcc agc ctt atc cca ac-3') paired on exon 2 and IVS II of the β -globin gene. The 50 μ L of reaction composed of 2.5 mM $MgCl_2$, 0.2 mM dNTPs, 0.4 μ M primers, 1x *Taq* buffer, and 1 unit of *Taq* DNA polymerase. After the hot start, 40 cycles of were performed with denaturation at 94°C 45 seconds, annealing 65°C with the step down of 0.5°C in each cycle, and extension at 72°C for 1.30 minutes. After the final extension for 7 minutes and store at 4°C before used, their nucleotide sequences were detected using chain terminator cycle sequencing (BigDye Terminator) with ABI Prism 310 Genetic Analyzer, Applied Biosystem) as described by the manufacturer. The relation of each mutation and each SNP as a marker for haplotyping, and locations and sizes of amplicons on the β -globin gene were shown in figure 1.

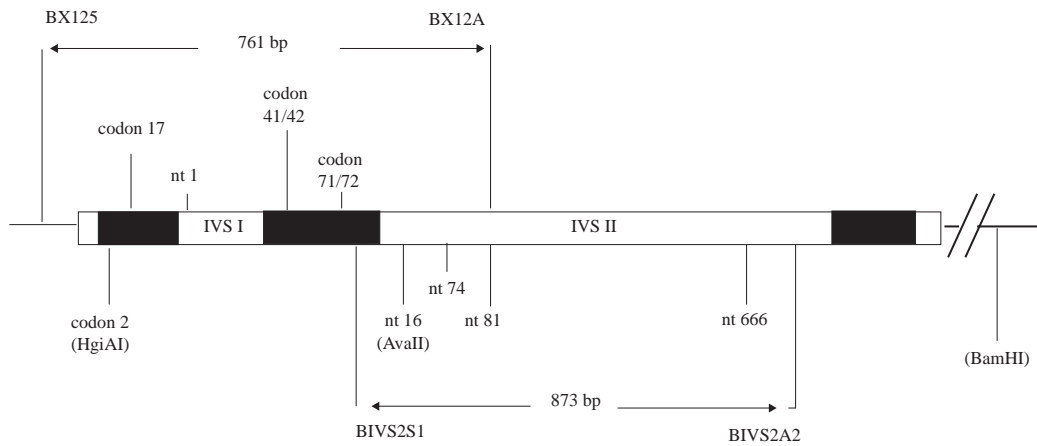

Figure 1 : A schematic diagram representing the relationship of each mutation and each SNP on the β -globin gene. The primer BX12S and BX12A were previously reported¹³.

3. RESULTS

All of 11 patients with homozygous of codon 17 (A-T) and both patients with homozygous of codon 71/72 (+A) were homozygous of FW3A, while the three patients with homozygous of Intron I nt 1 (G-T) were homozygous of FW1. However, in 15 patients with homozygous of codon 41/42 (-TCTT), eight of them were homozygous of framework (FW) 1, one was homozygous of FW3A, and the rest six patients were heterozygous of FW1 and FW3A. The gene frequencies of FW1 and FW3A in the patients with homozygous of codon 41/42 (-TCTT) were 0.733 (22/30) and 0.267 (8/30), respectively.

4. DISCUSSION

In this report, association of β -thalassemia mutations with the β -globin gene frameworks coincided with the majority reports^(6-10,14-17). With the exception in codon 41/42 (-TCTT), there is only one type of β -globin gene framework in each β -thalassemia mutations in this study. Unlike the previous study which all three frameworks capable to detect by restriction analysis were found in central Thailand⁽¹⁵⁾, there was no FW2 associated with the mutation in codon 41/42 in this report. This result may be due to differences in geographical origins of the patients examined in two studies. All our patients were living in northern Thailand, whereas their⁽¹⁵⁾ were from middle part of the countries. Our current method can only demonstrate the absence of four consecutive base pairs in codon 41 and 42 (TTCTTT-TT), which three possibilities of base pairs missing such as TTCT, TCTT, or CTTT. Association of two frameworks in codon 41/42 (-TCTT) may indicate multiple origin of the mutation in this region. This is similar to the purpose of the origin of hemoglobin E in Southeast Asia from the probabilities of crossing over

and recurrent mutations⁽⁵⁾. There has been extensively discussed and reviewed about the implication of the spread of this mutation to different frameworks on its origin and migration⁽¹⁵⁾. Further studies with micro-haplotype silence mutations in the neighboring nucleotide sequencing may provide more insight. This investigation, together with other population studies, may provide information for the study of the evolution of common mutations causing β -thalassemia major in northern Thailand.

REFERENCES

1. Weatherall, D., Clegg, J. (2001), *The Thalassemia Syndrome*. 4th ed: Blackwell Science.
2. Wasi, P., Pootrakul, S., Pootrakul, P., Pravatmuang, P., Winichagoon, P., Fucharoen, S. (1980), *Thalassemia in Thailand*. *Ann N Y Acad Sci* , pp. 344, 352-63.
3. Forget, B.G. (2001), *The β -thalassemias*. In: Steinberg MH, Forget BG, Higgs DR, Nagel RL, editors. *Disorders of Hemoglobin: Genetics, Pathophysiology, and Clinical Management*: Cambridge University Press, pp. 231-232.
4. Sirichotiyakul, S., Saetang, R., Sanguansermisri, T. (2003), *Hemoglobin*, vol. 27, no. 2, pp. 89-95.
5. Antonarakis, S.E., Orkin, S.H., Kazazian, H.H. Jr., Goff, S.C., Boehm, C.D., Waber, P.G., Sexton, J.P., Ostrer, H., Fairbanks, V.F., Chakravarti, A. (1982), *Proc Natl Acad Sci USA*, vol. 79, no. 21, pp. 6608-6611.
6. Orkin, S.H., Kazazian HH. Jr., Antonarakis, S.E., Goff, S.C., Boehm, C.D., Sexton, J.P., Waber, P.G., Giardina, P.J.V. (1982), *Nature*, vol. 296, no. 5858, pp. 627-631.
7. Antonarakis, S.E., Boehm, C.D., Giardina, P.J., Kazazian, H.H. Jr. (1982), *Proc Natl Acad Sci U S A* vol. 79, no. 1, pp. 137-141.
8. Laig, M., Sanguansermisri, T., Wiangnon, S., Hundrieser, J., Pape, M., Flatz, G. (1989), *Hum Genet*, vol. 84, no. 1, pp. 47-50.
9. Fukumaki, Y., Fucharoen, S., Fucharoen, G., Okamoto, N., Ichinose, M., Jetsrisuparb, A., Jetsrisuparb, A., Sriroongrueng, W., Nopparatana, C., Laosombat, V., Panich, V., Winichagoon, P., Tanphaichitr, V., Suvatte, V., Tuchinda, S. (1992), *Southeast Asian J Trop Med Public Health*, vol. 23(Suppl 2), pp. 14-21.
10. Lee, Y.J., Park, S.S., Kim, J.Y., Cho, H.I. (2002), *J Korean Med Sci*, vol. 17, no. 4, pp. 475-478.
11. Sambrook, J., Russell, D.W. (2001), *Molecular Cloning: A Laboratory Manual*. 3 ed: Cold Spring Harbor Laboratory.
12. Walsh, P.S., Metzger, D.A. (1991), *Biotechniques*, vol. 10, no. 4, pp. 506-513.
13. Sanguansermisri T., Thanarattanakorn, P., Steger, H.F., Tongsong, T., Chanprapaph, P., Wanpirak, C., Siriwatanapa, P., Sirichotiyakul, S., Flatz, G. (2001) , *Hemoglobin*, vol. 25, no. 1, pp. 19-27.
14. Varawalla, N.Y., Fitches, A.C., Old, J.M. (1992), *Hum Genet*, vol. 90, no. 4, pp. 443-449.
15. Fukumaki, Y., Fucharoen, S. (1991), In: Kimura M, Takahata N, editors. *New Aspects of the Genetics of Molecular Evolution*. Berlin: Springer-Verlag, pp. 153-176.
16. Furuumi, H., Firdous, N., Inoue, T., Ohta, H., Winichagoon, P., Fucharoen, S., Fukumaki, Y. (1998), *Hemoglobin*, vol. 22, no. 2, pp. 141-151.
17. Kotea, N., Ramasawmy, R., Lu, C.Y., Fa, N.S., Gerard, N., Beesoon, S., Ducrocq, R., Surrum, S.K., Nagel, R.L., Krishnamoorthy, R. (2000), *Am J Hematol*, vol. 63, no. 1, pp. 11-15.