

# Mathematical methods and software tools for designing and economic analysis of hybrid energy system

Ayodele T.R\* and Ogunjuyigbe A.S.O

Department of Electrical and Electronic Engineering, Faculty of Technology  
University of Ibadan, Nigeria

tr.ayodele@ui.edu.ng, a.ogunjuyigbe@ui.edu.ng

\*Corresponding author: Ayodele T.R, tayodele2001@yahoo.com, +2348064339270

## Abstract

Sometimes, it is difficult to select the appropriate method and software package necessary to accomplish a task out of the various available options. This often results in time wastage and frustration. This paper therefore explores the capabilities and the deficiencies of some of the mathematical techniques and software tools available for economic analysis and design of hybrid energy systems with the aim of pointing out the strength and the weakness of these various software tools. This will allow the end users to know the capabilities and the limitations of the various software options in hybrid energy design project. This contribution is useful to the engineers, energy planners, utility operators and general users to make an informed decision on the methods and software tools to be selected in designing hybrid energy system.

**Keywords:** Hybrid energy system, Software tool, Mathematical methods, Economic analysis

## 1. Introduction

Hybrid Energy System (HES) composed of different conventional energy generators, renewable energy generators, storage devices, converters and miscellaneous loads that can exist as a standalone system or connected to a mini-grid/national grid which may be centralized or distributed. It is an excellent solution for rural areas where the grid extension is difficult and uneconomical when operating as a standalone system [1, 2]. It offers a cost effective solution in contrast to extending the utility grid in remote areas. A HES offers the advantage that the strengths of each type of source can be used to complement one another. For example, the capital cost of wind turbine or PV generators is higher than that of diesel generator, but the operation and maintenance is lower and diesel is available all the time. Therefore, stand-alone HES usually incur lower costs and demonstrate higher reliability than photovoltaic (PV) or wind systems only [3]. Figure 1 depicts a typical hybrid energy system consisting of Wind/PV/battery/Diesel generators.

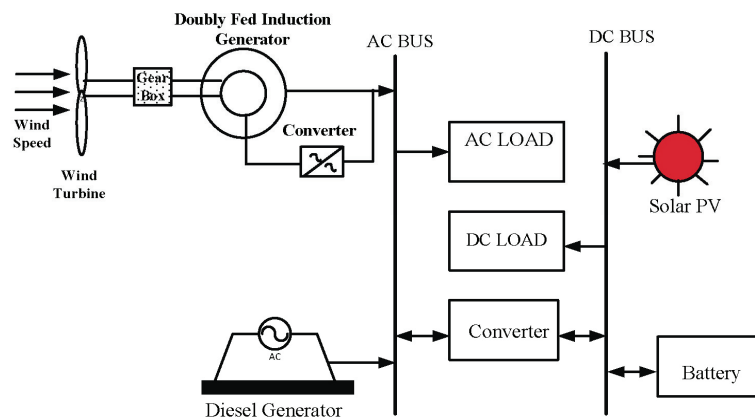

Figure 1. A typical hybrid energy system consisting of Wind-PV-battery-Diesel generators.

There have always been tendencies to assume that hybrid energy systems refer only to energy systems consisting of two or more renewable energy sources. For example, it was assumed in [4-6] that HESs is the combinations of two or more renewable energy sources. On the other hand, references [7-9] described HESs as combinations of two or more energy conversion devices which may be generators, storage devices, two or more fuels for the same device, that when integrated, overcome limitations that may be inherent in the other. This view is more general, thereby, allowing a wide range of possible system arrangements and multiplicity of energy conversion. HES offer potential for increasing system efficiency as well as maintaining good balance in energy supply. It can address limitations in terms of fuel flexibility, efficiency, reliability, emissions and/or economics [10, 11].

Several configurations of HES have been proposed in the literature. A biomass gasifier based HES was proposed in [8] for meeting the energy demand of rural communities. The proposed HES was based on the metrological load data from a typical village. It was concluded that gasifier based HES can optimally meet the electrical demand of rural communities. Muralikrishna and Lakshminarayana believed that for all load demands, the levelised cost of energy for PV-wind hybrid system is always lower than that of standalone solar PV or wind system [11]. Barsoun and Vacent [12] emphasised on the hydrogen hybrid power system for a small and remotely located communities. It was shown in their work that the system has the capability of providing reliable autonomous system for electricity generation for such communities. Feasibility analysis of a renewable energy dominated power structure in terms of both technological and economic considerations for the Hainan Island of China was a focus in [13]. The study showed that based on the renewable energy resource of the site, HES consisting of only renewable energy sources can meet the power demand of the island with competitive cost of energy of \$0.074/kWh and carbon emission reduction of 69.2%–74.9% compared to diesel generators only. Optimization planning model of HES consisting of wind power, solar power, and micro-turbine was developed by Fu and Wang [14]. In their model, the gain of optimal selection of HES was demonstrated using minimization of the total net present cost as the optimization goal. The authors also presented the sensitivity analysis of wind speed, natural gas price and emission punishment in the optimization results. Several HES was investigated for remote area of Thailand in order to determine the most suitable option in term of economic and optimum power supply in [15]. It was concluded that the most economical system to meet the load demand is Wind-Diesel-Battery-Inverter system. It was however reported that the optimum HES suitable for the site in Thailand is the PV-Wind-Diesel-Battery-Inverter combination. Saravia *et al* 2012 focuses on the development of the technical and economic analysis of integrating or combining the Otto cycle of a landfill-biogas fired Internal Combustion Engine (ICE) and the Organic Rankine Cycle (ORC). In their work, the conceptual design methodology for a combined cycle which integrates ICE and ORC technologies was developed[16].

All the aforementioned studies were carried out by the various authors using different mathematical models and software tools. One common challenge here is the ability to arrive at a decision about the mathematical methods and simulation package that should be adopted for the design and analysis of hybrid energy system. This is time consuming and frustrating. This present work is intended to bridge this gap by providing comprehensive information on the various mathematical methods and the software tools that are available for designing and economic analysis of HES with the aim of bringing out their strengths and the weaknesses. This will in turn provide the users the ability to make an informed decision on various available designed options for HES.

## 2. Appraisal of hybrid energy system

The decision whether to accept or reject a HES design for a given location depends on the objective for which the project is intended such as economic viability, emission efficiency, cost of energy etc. Therefore, there is always a need to appraise the design in order to determine if the objective is met. Some of the methods for appraising HES after the design to determine its suitability are Net Present Value (NPV), Net Present Cost (NPC), Carbon Emission Intensity (CEI) and Cost of Energy (COE).

### 2.1 Net present value

A Net Present Value (NPV) is one of the most popular ways of weighing costs against benefits of a project in which there are several alternatives to choose from. Net Present Value is defined as the net equivalent amount at present that represents the difference between the equivalent receipts and the equivalent disbursements of an investment cash flow for a selected discount rate. The net present value of an investment indicates how a given investment compares with alternative investments. For a proposed investment, a positive NPV shows profitability and a negative NPV otherwise. For a series of alternatives, the one with the highest NPV is the most beneficial of the lot. Equation (1) gives the generic formula for calculating NPV, where the net cash inflow (benefits minus costs) is summed up for each year starting from  $t = 0$  (beginning of project) to  $t = n$  (end of project), with each value discounted using a discount rate  $d$ .

$$NPV = \sum_{t=0}^{t=n} B_t (1+d)^{-t} - \sum_{t=0}^{t=n} C_t (1+d)^{-t} \quad (1)$$

### 2.2 Net present cost

The Net Present Cost of a project is a summation of all costs involved in a given project. An energy project for example will have a total net present cost comprising of the following costs: capital investment, non-fuel operation and maintenance costs, replacement costs, energy costs (fuel cost plus any associated costs), and any other costs. If a number of options are being considered then the option with the lowest Net Present Cost will be the most favourable financial option. When alternatives have same life expectancy and cost then the only major consideration is the NPC [6]. It can be mathematically written as (2)

$$C_{NPC} = C_O + C_{rep} + \sum_{t=1}^N \frac{C_t}{(1+i)^t} - SV \quad (2)$$

$$CA = C_{NPC} * CRF \quad (3)$$

where  $C_{NPC}$  is the NPC of a project,  $C_O$  is the cost of initial investment,  $C_{rep}$  is the replacement cost (at  $t = 0$ ),  $C_t$  is the expenses in year  $t$ ,  $SV$  is the salvage value (at  $t = 0$ ), and  $CRF$  is the Capital Recovery Factor.

$$CRF = \frac{i(1+i)^N}{(1+i)^N - 1} \quad (4)$$

Where  $N$  is the number of year of the project is also known as project lifetime and  $i$  is the annual interest rate for the project lifetime.

### 2.3 Carbon Emission Intensity

Another appraisal used in determining the viability of HES is the Carbon Emission Intensity (CEI). This is a useful index especially when environmental impact assessment is the focus. It can be calculated as equation (5)

$$CEI = \sum_1^5 (E_i * P_i) \quad (5)$$

where  $E_i$  is carbon intensity of each kind of power source (gCO<sub>2</sub>-e/kWh),  $P_i$  is the weight of each kind of power source (%).

#### 2.4 Cost of energy (CoE)

Cost of Energy (COE) is the price at which electricity can be generated from a given source to break even [17]. It is an economic assessment of energy generating plant which includes all the costs over its life period such as the initial investment and the operation and maintenance [18].

### 3. Hybrid Energy System Design Methods

The design of HES must be optimal in order to supply electricity reliably and economically [8, 19]. At present, there is no simple method to determine the best combination of HES that is well suited for a particular application due to the complexity and diversity of hybrid energy systems. The only way to seek solution to this problem is by modelling the HES [20]. This permits to have a good idea of the performances of the system at the least possible cost of generation. There are two main approaches in designing HES: the conventional methods and the mathematical model through computer algorithm approach.

#### 3.1 Conventional approach

This approach provides pragmatic guidelines on best practices involved in the sizing and operation of hybrid systems based on experiences with installed systems. These approaches are rule of thumb method and Ampere hour method.

##### 3.1.1 Rule of thumb method

Rule of thumb methods offer a rather primitive analysis of hybrid systems. The analytical process is done in order to choose a system with a particular configuration out of several alternatives. It involves consulting a predefined rule and finding a system configuration that best fits the intended environment and purpose. Rule of thumb methods are easy to use as design guidelines are sourced from experience. The rules comprises of a lot of technical details gotten from expertise. These details are often difficult to capture as the design is based on experience. The advantage of this method is that it does not involve rigorous calculation and hence can be easily understood by wider range of designers. However, they have their limitations. It is not accurate and may not be suitable for huge project. It can only give wide intuitive or 'rough' estimations and recommendations which might still be open to improvement by a computer based technique. Some of the most common rules of the thumb are depicted in Table I

Table I Rule of Thumb Design [21]

DESIGN		Rule of Thumb
SIZING	Renewable energy sizing	40%-60%
	Diesel generator size	Peak load demand in Watt
	Battery size	1 day of battery storage
	Inverter size	Peak (surge) load in Watt
	Battery charger size	Maximum charge current, Diesel capacity rating
	DC Bus voltage	24V-48V (<5kW), 96V (=5kW), 120V (>5kW)
OPERATION	Diesel generator operation	Load factor $\geq$ 50%
	Battery operation	40% maximum DoD, regular equalization, topping up with water
LOAD PROFILE	Household load	150Wh/day (DC), 1kWh/day (AC)

### 3.1.2 Ampere hour method

Ampere hour method begins by estimating the load profile in which the HES is intended to be designed. All loads are calculated with their power ratings in Watt which are multiplied by the number of hours run each day to obtain the total load demand in Wh/day [21]. Thereafter, the load in ampere hour per day (Ah/day) can be evaluated by dividing the estimated load profile (Wh/day) by the system voltage. In this way, the number of batteries in series and parallel can be determined for a chosen DC bus voltage once the battery storage requirement in number of days, the maximum discharge specification and a given selected battery size in Ah are known. To determine the number of panels of a chosen PV module, the calculated load in Ah/day is divided by the number of peak sun hours per day for different tilt angles. This will yield values of the DC bus current that will enable us to determine the number of panels of a chosen PV module. The number of modules in series is calculated by dividing the DC bus voltage through the panel operating voltage.

The beauty of Ampere hour methods is in its simplicity, ease of usage and ability to implement the method with spread sheets such as Microsoft excel. However, the method is time consuming compared to the computer based approach. Ampere hour method work well with solar PV but other renewable energy sources, such as wind turbines, cannot be included [21]. Also the intermittent nature of weather conditions cannot be incorporated with this method.

### 3.2 Mathematical model through computer algorithm

A more rational and exact method of designing and analysing hybrid energy systems is by way of mathematical modelling. As a result of the difficulty in determining the amount of useful energy produced by the renewable energy generators in a hybrid system and predicting the actual fuel savings, detailed computer models are frequently used to facilitate the process [2]. A mathematical model utilizes equation to describe the workings of a system. After a mathematical model has been created for a system, a computer algorithm can then be designed to implement it. Based on a hybrid system performance formulation, a model can be structured which can be optimized for a set of decision variables using some type of computer algorithm. Thereby the formulated objective function, usually the life cycle costs, is aimed to be minimized while meeting constraints placed on the system and performance [21]. The mathematical model for used for describing a hybrid system contains the following elements:

#### 3.2.1 Optimisation techniques

The description of a hybrid energy system by an appropriate mathematical model is just the first phase involved in the analysis of hybrid energy systems for configuration comparison. Optimisation helps in identifying what can be done (or not) to make a particular system perform better.

The optimisation problem is defined as minimizing a function  $F(X)$  through optimizing the values of its variables  $X$  [22]:

$$\begin{aligned} & \text{Min } F(\bar{X}) \\ & \bar{X} = \begin{bmatrix} X_1 \\ X_2 \\ \dots \\ X_n \end{bmatrix} \text{ or } \bar{X} = [X_i]_m \quad i=1,2,\dots,m \end{aligned} \quad (6)$$

Often times constraints, expressed as  $g(x)$ , are placed on the system and its performance. The solution of the optimization problem needs to lie within these constraints [21, 22].

$$h(X) \geq 0 \quad (7)$$

$$\bar{h} = \begin{bmatrix} h_1 \\ h_2 \\ \dots \\ h_j \end{bmatrix} \text{ or } h = [h_k]_q \quad k=1,2,\dots,q$$

Therefore the goal of the optimization procedure is to find a vector  $X$  that minimizes the real-valued function  $F(X)$  while satisfying the constraints  $h(X)$ . The function  $F(X)$  is called the cost, objective or energy function and  $X$  is an  $n$  dimensional vector called the design vector.

#### 4. Software based hybrid energy system economic analysis

The utilization of computer software for the design and analysis of hybrid energy system is the natural progression of the mathematical models describing hybrid energy system and corresponding step-by-step procedural algorithm that becomes adopted and implemented in a given computer software. Most of these software tools simulate a predefined hybrid system based on a mathematical description of the component characteristic operation and system energy flow and often incorporate financial costing of the system configuration. These packages are valuable to assess a certain hybrid system design and enable to view the effects of changing component sizes and settings manually [21]. However, many of these software tools required a hybrid system having being predesign by other means such as the rule-of-the methods. A brief overview of some of the software tools available for hybrid system design and analysis is given below.

##### 4.1 HYBRID2

Hybrid2 is a simulation package written in visual basic and developed at Renewable Energy Research Laboratory (RERL) of the University of Massachusetts. The software makes use of probabilistic-time series approach in order to predict the performance of HES. It is established software for the simulation and analysis of both the technical and economic aspect of HES. It allows the user to select the time series load, wind speed and solar insolation to predict the performance of HES. The software offers the user a range of systems, components, control and dispatching options modelling with user specified time steps. It has the capability to produce the output parameters of interest in form of XY graph and histogram. It can also store ASCII files of output data for subsequent analysis at the user's convenient time [23]. This tool has been extensively validated [21].

##### 4.2 HOMER

HOMER is a micro-power optimization modelling tool which was developed by the National Renewable Energy Laboratory (NREL) of the United States Department of Energy (DOE) for the Village Power program. HOMER provides an efficient and methodological way of making informed decisions about designing and constructing a hybrid energy system. The software tool has the capability to determine the system configuration, system components and sizing, cost and availability of resources and the large number of technology options available. Its main advantage over many other hybrid energy system design software is that it can easily help simplify complex hybrid energy design and make an informed decision on difficult situations.

HOMER simulated the operation of the system by making energy balance calculations for each of the 8,760 hours in a year. For each hour, HOMER compared the electric and thermal demand in the hour to the energy that the system can supply in that hour, and calculated the flows of energy to and from each component of the system [24]. For systems that include batteries or fuel-powered generators, HOMER will be used to decide for each hour how to operate the generators and whether

to charge or discharge the batteries. For each system configuration under consideration, HOMER will perform these energy balance calculations and then determines whether a configuration is feasible, i.e., whether it can meet the electric demand under the conditions that is specified, and estimates the cost of installing and operating the system over the lifetime of the project [24]. The system cost calculations account for costs such as capital, replacement, operation and maintenance, fuel, and interest. The software has the capability to perform system optimization. The optimization process determined the best possible system configuration from a range of options [25]. Another interesting capability of the software program is its ability to perform sensitivity analysis. The sensitivity analysis will allow one to see how results obtained from simulation and optimization varies with changes in unpredictable inputs, such as fuel costs and solar radiation.

#### 4.3 RETScreen

RETScreen is a product of coordinated work of various industry, academia and Canadian Government available in 35 languages [26]. The software is basically a decision support tool. It has the capability to simulate the energy production and savings from renewable energy and energy efficient technologies. It can evaluate the project costs, emission of greenhouse gas, financial viability and the risk involves in a projects [26]. The tool is a Microsoft Excel-based free software package used to determine the technical and financial feasibility of clean energy projects, which includes renewable energy installations and the means to assess a wide range of energy efficiency options. The software also integrates a number of databases to assist in a project's appraisal; this includes a global database of climatic conditions obtained from ground-based stations and NASA's satellite data.

RETScreen is managed under the leadership and on-going financial support of the CanmetENERGY research centre of Natural Resources Canada, a department of the Government of Canada. The package work well on the platform of Microsoft® Excel 2000 or higher.

#### 4.4 System advisor model

The System Advisor Model (SAM) is a performance and economic model designed to facilitate decision making for people involved in the renewable energy industry, ranging from project managers and engineers to incentive program designers, technology developers, and researchers. SAM makes performance predictions and cost of energy estimates for grid-connected power projects based on installation and operating costs and system design parameters that are specified as inputs to the model. The model calculates the cost of generating electricity based on information provided about a project's location, installation and operating costs, type of financing, applicable tax credits and incentives, and system specifications. SAM's spreadsheet interface allows for exchanging data with external models developed in Microsoft® Excel. The model provides options for parametric studies, sensitivity analysis, optimization, and statistical analyses to investigate impacts of variations and uncertainty in performance, cost, and financial parameters on model results. It has the capability to perform an hourly calculation for electric generation. It has the ability to model time of use utility rates and also to perform stochastic modelling [27].

#### 4.5 IMBY

In My Back Yard (IMBY) is a tool developed by NREL that estimates how much electricity you can produce through solar and wind power in your own backyard. IMBY is essentially a web based application that helps intending end users determine if their geographical location has wind and solar characteristics that might be economical sensible enough for them to consider generating electricity from them. This software has the capability to compare renewable energy generation output with actual load profile for a given year. However, the tool is geographically limited to applications in North America and can only be used as a quick check before detailed analysis.

#### 4.6 CREST

The Cost of Renewable Energy Spreadsheet Tool (CREST) came up as a product generated through the partnership between the National Renewable Energy Laboratory (NREL), Solar energy Technology Program (SETP), National Association of Regulatory Utility Commission (NARUC) and the US department of energy (DoE) [28]. The product was developed and validated by the Sustainable Energy Advantage (SEA) under the supervision of NREL in 2010. It is an economic cash flow model designed to allow policymakers, regulators, and the renewable energy community to assess project economics, design cost-based incentives (e.g., feed-in tariffs), and evaluate the impact of various state and federal support structures. CREST is a suite of five analytic tools, for solar (photovoltaic and solar thermal), wind, geothermal, fuel cell and anaerobic digestions technologies. The software has the capability to estimate the first year Cost of Energy (COE) and the Levelised Cost of Energy (LCOE) from a project involving wind, solar, geothermal, fuel cell [28]. It also has the capability to evaluate the cost of generation with different sensitivity scenario such as size, resource quality, location etc. However, this tool is less accurate and is usually used as quick check before detailed analysis. It majorly serves as a complementary tool before employing a more detailed SAM tool [27].

#### 4.7 TRNSYS

TRNSYS is a validated, time-series simulation program that can simulate the performance of photovoltaic, concentrating solar power, water heating systems, and other renewable energy systems using hourly resource data. It is commercially available simulation package developed in 1975 through an international collaboration of the United States, France, and Germany. The usable add-on components capability and the ability to interface with other simulation programs make it one of the most flexible user friendly energy simulation packages [26]. The Software allows the user to stipulate a system description language to specify the components that constitute the system and the manner in which they are connected. It can work on all versions of Windows and Windows emulators.

#### 4.8 WebOpt

The Distributed Energy Resources Web Optimization Service (WebOpt) is an optimization tool to minimize the cost or emissions for meeting electrical and thermal load demand of a microgrid based on a one-hour time step [29]. WebOpt is a mixed integer linear programming (MILP) tool based on the Distributed Energy Resources Customer Adoption Model (DER-CAM). It is freely web accessible version developed by the Lawrence Berkley Laboratory (LBL) and implemented on the General Algebraic Modeling System (GAMS). However, an advanced commercially available version (DER-CAM) is also available. This version consist of advance feature such as electric vehicle simulation option, stochastic programming and 5-min time step optimization [30] that are not obtainable in the free web accessible version. WebOpt has the capability to determine the best combination and capacity of the different Distribute Energy Resource (DER) technologies available to meet the desired goals of the user [30]. Constraints involved in the optimization process require that all end-use loads are met (unless the demand response option is utilized) and the thermodynamics of the system are obeyed. WebOpt (and DER-CAM) separates its technologies into two categories, continuous and discrete. Some available technologies in the software are the PV, fuel cell + heat exchanger (FC-HX), absorption chillers, batteries, internal combustion engine (ICE), etc.

#### 4.9 INSEL

INtegrated Simulation Environment Language (INSEL) is a graphical programming language for simulation of renewable energy system developed at the University of Oldenburg. It is commercially available software based on Graphical User Interface (GUI). The user selects blocks from its library and connects them in order to define the structure of the system which makes it user friendly and excellent for simulation. The blocks are put together by the user for the simulation of meteorological data, electrical and thermal energy constituents [26]. The modular simulation environment in which it is operating enhances the understand, planning, monitoring, and visualizing of hybrid energy systems.



The software package has databases for photovoltaic modules, inverters, thermal collectors and meteorological parameters. The application fields of INSEL contain a variety of graphical and numerical outputs either built-in or user defined. The software is basically used for solar irradiance simulation, photovoltaic and solar thermal applications. It is also used in determining the optimum PV module parameters, annual yield energy output of PV, efficiency comparisons of various PV axis tracking system and the efficiency gains or losses for tilted fixed angles. It can also be used to study cell temperature distribution and the performance of the cell, array, and plant. It works well on Windows 7, Windows Vista, and Windows XP.

#### 4.10 RAPSIM

Remote Area Power Supply Simulator (RAPSIM) [3] is a commercially available software package based on C++ for simulating hybrid system consisting of PV, wind, Diesel and Battery system. It originated from University of Murdoch in Australia. It has the ability to determine the total costs throughout the lifespan of a project. The effect of components on the overall system cost can be determined by the user by modifying the components.

#### 4.11 HOGA

Hybrid Optimization by Genetic Algorithms (HOGA) [31] is a free available software developed by the Electric Engineering Department of the University of Zaragoza in Spain. The tool is a hybrid system optimization program that is capable of carrying out optimization of hybrid energy system by means of Genetic Algorithm. The package is similar to HOMER in function but operate using genetic algorithm, which can be mono-objective or multi-objective [3]. It finds immediate application in hybrid system consisting of a PV generator, batteries, wind turbines, hydraulic turbine, AC generator, fuel cells, electrolyzer, hydrogen tank, rectifier, and inverter. The loads can be AC, DC, and/or hydrogen loads. The simulation is carried out using 1-hour intervals, during which all of the parameters remained constant.

#### 4.12 RAPSYS

RAPSYS is a HES simulation package developed in 1987 at the University of New South Wales Australia. It has the ability to simulate different component that may be incorporated into a system configuration. It is however not user friendly [21, 32] as it is designed to suit only the user who has the pre-knowledge of Remote Area Power Supply Simulator (RAPS) rather than the general users. The simulation package has the advantage that it has the ability to determine when the diesel generator should be switched on or off. The tool can be used to perform economic analysis but cannot be used for optimisation purposes.

#### 4.13 SOLSIM

SOLSIM is a hybrid energy system simulator developed at Fachhochschule Konstanz in Germany. It contains detail models for Wind turbines, PV panels, diesel generators, and batteries components. The software package also includes biogas and biomass generators for electricity generation. It can be used to simulate the operation of the system and has the ability to perform economic analysis. The control options are very limited, but can only optimize PV installation angle. This software is no more available [3].

#### 4.14 Solar advisor model

Solar Advisor Model (SAM) is a free hybrid energy simulator developed by National Renewable Energy Laboratory (NREL) and runs on TRNSYS engine [26, 33]. The software can be used to determine the economic viability of the direct and indirect solar power technology which includes concentrating solar power parabolic trough, Stirling-dish systems, photovoltaic flat plate and concentrating technologies. It has the ability to determine the levelized cost of electricity, system capital, operating and maintenance costs, system energy output, peak and annual system efficiency and hourly system production. The software has the capability of simulating renewable generation at a

device level thereby given the customer the opportunity to explore the payback period, annual energy output and the annual financial impact of such devices[34]. Solar advisor system is more for individual-level deployments. However, to be suitable for system level study, it has to be fused with software such as GridLAB-D [34].

#### 4.15 GridLAB-D™

GridLAB-D™ is a software package developed by the Pacific Northwest National Laboratory (PNNL) funded by the Department of Energy, Office of Electricity Delivery and Energy Reliability [34]. This tool finds application in modelling distribution systems from the sub-transmission system down to the final appliance in a customer's home or business. It is a power distribution simulation and analysis package used for designing and simulation of distribution system. It is useful to the users and the utilities who want to examine the impact of new technologies on the existing distribution system. It has the capability to evaluate the impact of new technologies on the distribution system. It can be integrated with solar advisor model to estimate the economic implication of solar photovoltaic technology on the existing distribution system [34].

### 5. Strength and weakness of the software tools

The strength and the weakness of the software are obtained from different literature and are classified in term of the software availability (free or commercial), accuracy, capability for economic analysis and suitability for hybrid design optimization. The classifications are depicted in Table II. The availability of the software in this paper is defined as the ease at which the software can be accessed (i.e freely available or commercially available for use). The accuracy of the software is based on the degree in which it can truly represent the practical system. Under the economic analysis, the focus is the capability of the softwares to be able to determine the cost effectiveness of the designed hybrid energy system in term of the NPC, NPV and the COE. The optimization criteria give the capability of the software to be able to determine the optimal size of the various components that makes up the hybrid energy system.

Table II Comparison of the strength and the weakness of software-based hybrid energy system in term of availability, accuracy and optimization

HES Software	Manufacturer	Availability	Accuracy	Economic Analysis	Optimization	Website
Hybrid2	RERL, University of Massachusetts	Free	High	Yes	Yes	<a href="http://www.ceere.org/rerl/projects/software/hybrid2/">http://www.ceere.org/rerl/projects/software/hybrid2/</a>
HOMMER	NREL, USA	Some free and some commercial	High	Yes	Yes	<a href="http://www.nrel.gov/homer">www.nrel.gov/homer</a>
RETscreen	Natural Resources Canada	Free	Low	Yes	No	<a href="http://www.retscreen.net">www.retscreen.net</a>
SAM	NREL	Free	Medium	Yes	Yes	<a href="http://www.nrel.gov/analysis/sam/">www.nrel.gov/analysis/sam/</a>
IMBY	NREL	Free	Low	Yes	No	<a href="http://www.financere.nrel.gov/content/crest-cost-energy-models">www.financere.nrel.gov/content/crest-cost-energy-models</a>
CREST	SEA and NREL	Free	Low	Yes	No	
TRNSYS	University of Wisconsin, Madison, US	Commercial	High	Yes	No	<a href="http://sel.me.wisc.edu/trnsys/">http://sel.me.wisc.edu/trnsys/</a>
INSEL	University of Oldenburg	Commercial	High	No	No	<a href="http://www.insel.eu">http://www.insel.eu</a>
RAPSIM	University of Murdoch Australia	Commercial	High	Yes	No	

HES Software	Manufacturer	Availability	Accuracy	Economic Analysis	Optimization	Website
WebOpt	Lawrence Berkley Laboratory	Free	Low	Yes	Yes	<a href="http://www.der.lbl.gov/der-cam">http://www.der.lbl.gov/der-cam</a>
HOGA	University of Zaragoza	Free	Low	Yes	Yes	<a href="http://www.unizar.es/rdufo/hoga-eng.htm">www.unizar.es/rdufo/hoga-eng.htm</a>
RAPSYS	University of South Wales	-	High	Yes	No	-
SOLSIM	Fachhochschule Konstanz Germany	Not available	High	Yes	Limited	<a href="http://www.fhkonstanz.de">http://www.fhkonstanz.de</a>
Solar Advisor Model	NREL, USA	Free	Low	Yes	No	<a href="https://www.nrel.gov/analysis/sam">https://www.nrel.gov/analysis/sam</a>
GridLAB-D	PNNL	Commercial	Medium	Yes if used with SAM	No	

## 6. Conclusion

This paper has explored the mathematical models and the various available simulation packages options for designing and evaluating the economic analysis of hybrid energy system. The paper shows that, no single software is complete on its own. The choice of the software for HES design depends on model of hybrid energy system under consideration and the level of accuracy required. Some HES design software are free and can be downloaded without any cost, however, it has been revealed through various literature as compiled in Table II that most of these free softwares are less accurate and hence may not accurately represent the true system. All the simulation packages are algorithmic implementations of mathematical models; hence, the accuracy in which they describe hybrid system depends on the accuracy of assumptions and the thoroughness of such models. In the future research, the various softwares are going to be applied to a specific case study and the results will be compared to bring out the similarity and discrepancy in their modelling ability.

## References

- Shiroudi A, Rashidi R, Gharehpetian G B, Mousavifar S A, and Foroud A A: Case study: Simulation and optimization of photovoltaic-wind-battery hybrid energy system in taleghan-iran using homer software. *Journal of Renewable and Sustainable Energy*, 4, (2012).
- Al-Badi A H and Bourdoucen H: Study and design of hybrid diesel-wind standalone system for remote area in oman. *International journal of Sustainable Energy*, 31, 85-94, (2011).
- Jose´ L, Bernal-Agustin R, and Dufo-Lo´ P: Simulation and optimization of stand-alone hybrid renewable energy systems. *Renewable and Sustainable Energy Reviews*, 13, 2111-2118, (2009).
- Ding J J and Buckeridge J S: Design considerations for a sustainable hybrid energy system. *IPENZ Transactions*, 27, 1-8, (2000).
- Bhattacharyya D and Roy P C: Hybrid energy system simulation for sustainable energy utilization. *International Journal of Emerging Technology and Advanced Engineering*, 3, 622-627, (2013).
- Pragya N and Sayan D: Feasibility study of 1 mw standalone hybrid energy system: For technical institutes. *Low Carbon Economy*, 3, 63-68, (2012).
- Manwell J F: Hybrid energy systems *Encyclopedia of Energy*, 3, 216, (2004).
- Ashok S and Balamurugan P, "Biomass gasifier based hybrid energy system for rural areas," presented at the IEEE Canada Electrical Power Conference, Montreal, Quebec, 2007.
- Injeti and Navuri P K: An efficient method for optimal placement and sizing of multiple distributed generators in a radial distribution systems. *Distributed Generation & Alternative Energy Journal*, 27, 52-71, (2012).
- Rehman S, Alam M M, Meyer J P, and Al-Hadhrami L M: Feasibility study of a wind–pv–diesel hybrid power system for a village. *Renewable Energy*, 38, 258, (2012).
- Muralikrishna M and Lakshminarayana V: Hybrid (solar and wind) energy systems for rural electrification. *ARPN Journal of Engineering and Applied Sciences*, 3, 50, (2008).

- 12 Barsoum N N and Vacent P, Balancing cost, operation and performance in integrated hydrogen hybrid energy system, in First Asia International Conference on Modelling & Simulation. (2007),
- 13 Bin Y, Jie T, Liji, Huang Jiemin H, and Xiaomei L, International conference on computer distributed control and intelligent enviromental monitoring, in Feasibility Study of Renewable Energy Powered Island-Hainan. 330-333. (12),
- 14 Fu L and Wang S X, "Optimal selection of multiple types of distributed generations," presented at the International Conference on Electrical and Control Engineering, Yichang, China, 2011.
- 15 Fung C C, Rattanongphisat W, and Nayar C, "A simulation study on the economic aspects of hybrid energy systems for remote islands in thailand," presented at the IEEE Region 10 Conference on Communications, Control and Power Engineering ( TENCON 002 ), Beijing, China, 2002.
- 16 Saravia J R, Vega-Galaz J R, Villena A C, and Ortiz J N: Technical and economical evaluation of landfill- biogas fired combined cycle plants. Distributed Generation & Alternative Energy Journal, 27, 7-25, (2012).
- 17 wikipedia. (2012, 18th June). *Levelised energy cost*. Available: [www.wikipedia.or/wiki/cost\\_of\\_electricity\\_by\\_source](http://www.wikipedia.or/wiki/cost_of_electricity_by_source)
- 18 Ayodele T R, Jimoh A A, Munda J L, and Agee J T: Viability and economic analysis of wind energy resource for power generation in johannesburg, south africa. International journal of Sustainable Energy, 33, 284–303, (2013).
- 19 Nagaraju K, Sivanagaraju S, Ramana T, and Ganesh V: Enhancement of voltage stability in distribution systems by optimal placement of distribution generator. Distributed Generation & Alternative Energy Journal, 27, 25-41, (2012).
- 20 Colin H and P B, Photovoltaic hybrid system modelling with hybrid 2 software, in PVHPS. (2000),
- 21 Seeling-Hochmuth G: Optimisation of hybrid energy systems sizing and operation control. Dr.-ing Thesis, Kassel University Press ISBN 3-933146-19-4, (1999).
- 22 Chichocki A and Unbehauen R, *Neural networks for optimisation and signal processing*: Chicester: Wiley, 1993.
- 23 Green H J and Manwell J F: Hybrid 2-a versatile model of the performance of hybrid power system. Renewable Energy Research Laboratory (RERL) of the University of Massachusetts, 1-6, (1994).
- 24 NREL: Getting started guide for homer version 2.1. Golden: US Department of Energy, (2005).
- 25 Lambert T and Lilienthal P, "Homer: The micro-power optimisation model (accessed 15th august 2013)," in <http://homerenergy.com/>, ed: National Renewable Energy Lab (NREL), 2004.
- 26 Lalwani M, Kothari D P, and Singh M: Investigation of solar photovoltaic simulation softwares. International Journal of Applied Engineering Research, Dindigul, 1, 585-601, (2010).
- 27 NREL: Distinctions between crest and nrel's system advisor model (sam) accessed 4th june 2014. <https://financere.nrel.gov/finance/content/crest-cost-energy-models>, (2014).
- 28 Gifford J S and Grace R C: Cost of renewable energy spread sheet (crest): A model for developing ost-based incentives in the united state. User Manual 1, National Renewable Laboratory NRL/SR-6A20-50374, 1-37, (2011).
- 29 DER-CAM: Distributed energy resources customer adoption model, lawrence berkeley national laboratory [online]. Available.: <http://www.der.lbl.gov/der-cam>, (2014).
- 30 Litchy A J, Young C, Pourmousavi S A, and Nehrir M H, "Technology selection and unit sizing for a combined heat and power microgrid: Comparison of webopt and homer application programs," presented at the North American Power Symposium, USA, 2012.
- 31 Dufo-Lo'pez R and Bernal-Agustin J L: Design and control strategies of pv–diesel systems using genetic algorithms. Solar Energy 79, 33-46, (2005).
- 32 Borchers M L, "Raps computer tools," B.Sc, Department of Mineral and Energy Affair, University of Cape Town, Cape Town, 1993.
- 33 NREL: National renewable energy laboratory”, accessed on 12th march. <https://www.nrel.gov/analysis/sam>, (2014).
- 34 Tuffner F K, Hammerstrom J L, and Singh R: Incorporation of nrl solar advisor model photovoltaic capabilities with gridlab-d. Pacific Northwest National Laboratory DE-AC05-76RL01830, 1-36, (2012).