

The effect of distributed grid-connected photovoltaic power systems on low voltage utility supply

Ahmad Maliki Omar *, Faranadia Abdul Haris and Sulaiman Shaari

Green Energy Research Centre,
Faculty of Electrical Engineering,
University of Technology MARA (UiTM)
Shah Alam, Malaysia

Email: faranadia88@gmail.com and solarman1001@gmail.com

*Corresponding author: maliki_omar@salam.uitm.edu.my

Abstract

This paper describes the effect of Grid-Connected Photovoltaic (GCPV) power system on the low voltage utility power supply based on Malaysian climate variations. Detailed analysis on the issues has been conducted based on the theoretical concept using phasor diagrams covering effects on both, load side as well as the utility power supply side. The theoretical concept is validated using actual data measurement carried out at Green Energy Research Centre (GERC), Universiti Teknologi MARA (UiTM) Shah Alam, Selangor. The prediction and detailed analysis of electrical parameters were carried out using MathCAD software. The results show good agreement between predicted and actual data.

Keywords: *Grid-connected photovoltaic (GCPV), power quality prediction*

1. Introduction

There has been significant growth of grid-connected photovoltaic (GCPV) system installations in recent years in Malaysia due to the introduction of feed-in tariff (FIT) system. The FIT system is managed by Sustainable Energy Authority (SEDA) Malaysia [1]. The Distribution Licensee (DL), i.e. a body that is given the license to distribute electricity, such as Tenaga Nasional Berhad (TNB), will pay for renewable energy supplied to the grid for 21 years. Since the output of a PV system is largely influenced by solar irradiance and module temperature [2], with the significant numbers, coupled with the relative size of the grid in Malaysia, the effects coming from a GCPV system subjected to climate variations on the grid is considered a potential concern by the electricity industry [3-5].

In this paper the effect on power factor (PF) and AC voltage are focused. Although harmonic contents give significant impact on the quality of the grid supply [6-7], its study requires empirical data on the harmonics injection. This study gives a theoretical background using fundamental concept through phasor diagram to explain the behaviour of the system. The theoretical results are supported by actual measurement using actual data obtained from the GCPV system installed in Green Energy Research Centre (GERC) Universiti Teknologi MARA (UiTM).

2. Theoretical Background

A PV device is a unique type of current source which has non-linear I-V characteristics with limited maximum current. This is very different from conventional power generation sources. Due to its characteristics, the PV modules can be short circuited without damaging them and sometimes it is required to do short circuit tests as per required by typical testing and commissioning (T&C) procedures. Besides, it is impossible for the PV module to produce DC current greater than short circuit current during typical operating conditions.

In an operational GCPV system, a key component is the grid-interactive inverter. One of its main features is the ability to operate at unity power factor. Hence, almost all power that is injected to the grid is active power, with no reactive power generation. However, consuming only reactive power from the grid is not a favourable operating condition for the utility.

Coupling the characteristics of the PV and grid-interactive inverter with the weather conditions in Malaysia, the abrupt variability of power generation creates power quality issues. As the number of GCPV systems gets larger, its effect on the utility grid becomes significant. Thus, it is important to highlight the issues for all stakeholders, so that early preparation could be done to reduce undesirable effects.

3. Methodology

This section presents the theoretical concept using phasor diagrams to predict the behaviour of electrical system with contribution of power from GCPV system. The phasor diagram could explain the effect of GCPV system on voltage, power factor and reactive power at the load side. A simplified single line diagram of electrical network model used in this study is shown in the Fig. 1. The voltage at the point of common coupling which is at the load side is denoted as V_g , voltage at the terminal output of sub-station as V_s and current generated from GCPV system which is weather dependent as I_p . Current from incoming cable which is grid current is denoted as I_g . The line impedance is represented by $R + jXL$. The load consists of equipment in an administrative office. For simplicity, the operation of the system is divided into three cases.

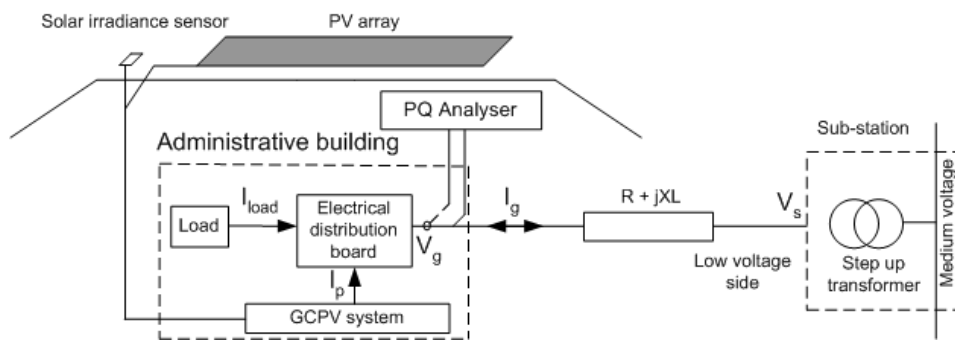

Figure 1. Model for GCPV system with direction of current flow

Case 1: Current generated from GCPV system is less than load current.

The current generated from the GCPV system depends on weather conditions. At low solar irradiance especially early in the morning or late evening, the current is low. As the sun rises in the morning, the GCPV current increases from I_{p1} to I_{p2} and GCPV current reduces from I_{g1} to I_{g2} as shown in Fig. 2(a) and Eq. 1. In most cases, the current produced by GCPV is not adequate to support the load, thus the load current partly comes from grid line.

It is also expected that the voltage at the load terminal increases from V_{g1} to V_{g2} as equated in Eq. 2. The maximum limit of V_g is V_s . As the GCPV current increases, the power factor drops as shown in Eq. 3. The power factor is in lagging mode.

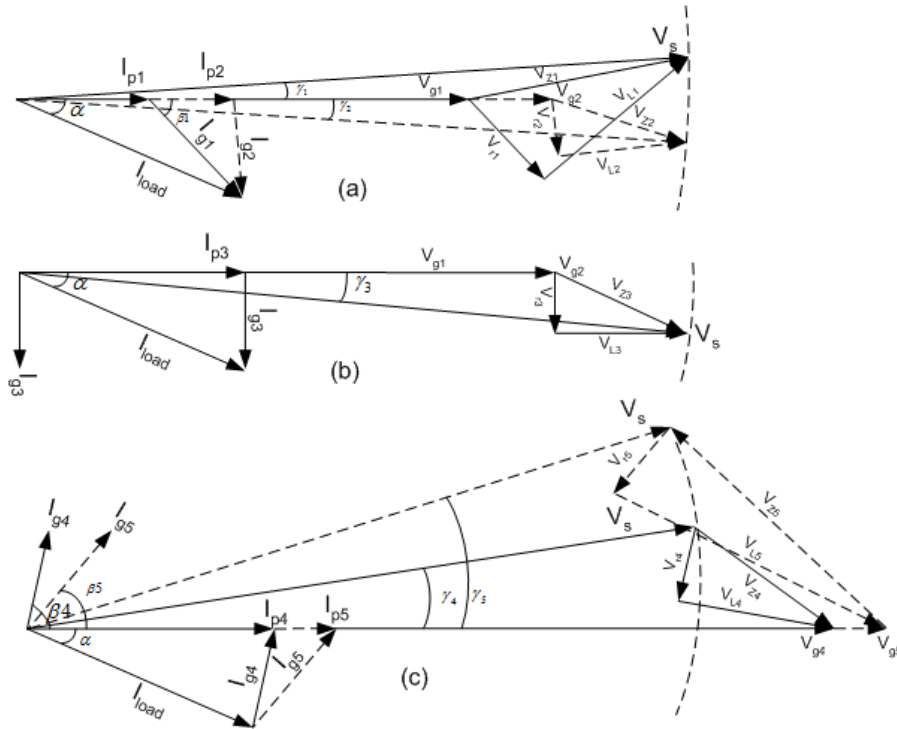

Figure 2 Phasor diagram for current from GCPV system. (a) GCPV current is less than load current (b) GCPV current is equal to load current (c) GCPV current is greater than load current.

$$I_{g1} \angle (-\beta_1) = I_{load} \angle (-\alpha) - I_{p1} \quad (1)$$

$$V_{g1} = V_s \angle \gamma_1 - I_{g1} \angle (-\beta_1) \{ (R + jX_L) \} \quad (2)$$

$$PF_1 = \cos(\beta_1) = \frac{I_{load} \cos(\alpha) - I_{p1}}{I_{g1}} \quad (3)$$

Case 2: Current generated from GCPV is equal to active load current

The inverter of GCPV system is commonly configured to operate at unity power factor. Thus, the GCPV inverter only generates active power. As the GCPV current increases, at one instant the current generated from GCPV is equal to the active load current. Thus, reactive load power is solely supplied by the grid. The phasor diagram during this case is shown in Fig. 2(b).

$$I_{g3} \angle (-90) = I_{load} \angle (-\alpha) - I_{p3} \quad (4)$$

$$V_{g2} = V_s \angle (-\gamma_3) - I_{g3} \angle (-90) \{ (R + jX_L) \} \quad (5)$$

$$PF_1 = \cos(-90) = 0 \quad (6)$$

During this condition, current drawn from the grid I_g is the lowest as shown in Fig. 2(b) and Eq. 4. The load terminal voltage is expected to slightly increase as indicated in Eq. 5. However, the power factor is the worst as shown in Eq. 6.

Case 3: Current generated from GCPV system is greater than load current.

At high solar irradiance, more current is generated from the GCPV system. In this case, active power generated from GCPV system is more than enough to supply active load power. Some of the surplus flows to the grid. The phasor diagram during this condition is shown in Fig. 2(c).

The terminal voltage at the load side could be high if the voltage at the sub-station terminal is high. Usually the utility set the voltage V_s higher to compensate higher voltage drop during large current flows to the load. However, during low load, the voltage appears at the load side is high. Thus, the load terminal

voltage could be higher and might exceed the maximum operating limit of the inverter. Longer distribution cable from the load and the sub-station also might increase the voltage at the load side.

$$I_{g4} \angle \beta_4 = I_{p4} - I_{load} \angle \alpha \tag{7}$$

$$V_{g4} = V_s \angle \gamma_1 - I_{g4} \angle \beta_4 (R + jX_L) \tag{8}$$

$$PF_4 = \cos(\beta_4) = \frac{I_{p4} - I_{load} \cos(\alpha)}{I_{g4}} \tag{9}$$

As the GCPV current increases, current transfer to the grid also increases as shown in Fig.2(c) and Eq. 7. It is expected that the voltage at the load side is higher than the voltage at the sub-station terminal. It is important to note that the power factor changes direction from lagging to leading mode and can be determined using Eq. 9.

4. Results and discussion

To validate the mathematical model developed, actual measurements were conducted at Green Energy Research Centre (GERC) in Universiti Teknologi MARA, Shah Alam, Selangor, Malaysia. The total PV capacity of GCPV system is 15.405 kWp. The power quality analyser was setup as shown in Fig. 1. A solar irradiance sensor is located on the roof top, near the PV array.

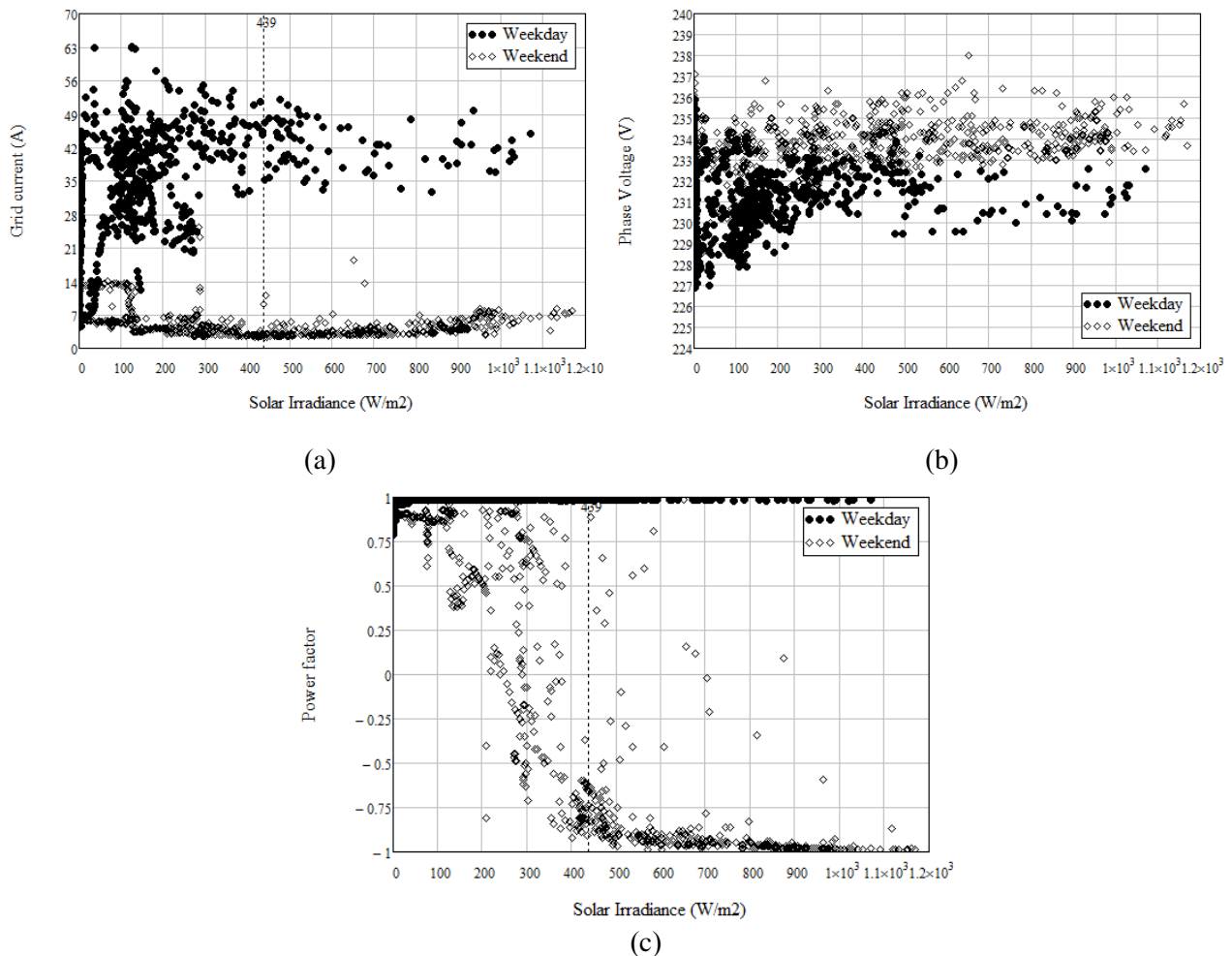

Figure 3. Condition of grid during weekday and weekend (a) Grid Current (b) Phase Voltage (c) Power factor.

All the cables from GCPV system are connected to a compact electrical distribution board in the administrative building. Data using a Power Quality Analyser were logged for seven days with a sampling rate of 1 minute. The solar irradiance, current from GCPV and voltage at load side were logged using built-in

datalogger in the inverter for one month with a sampling rate of 5 minute. During weekdays, the load consists of a centralised air-conditioning system, computer server, desktop computers lighting and usual office equipment. During weekend, only computer server is on and desktop computers in standby mode.

During weekdays, the load received current from the grid and GCPV system. As the solar irradiance increase, the grid current reduces as shown in Fig. 3(a). The voltage at the load side is observed slightly increased as the solar irradiance increased, Fig. 3(b). The power factor slightly drops at higher solar irradiance, Fig. 3(c). This is agreeable with the theoretical concept as previously discussed.

During weekends, some of the current generated from GCPV system is transferred to the grid. At solar irradiance 439 W/m^2 as shown in Fig. 3(a), the grid current is the lowest. At this point as the solar irradiance increases, power factor change mode from lagging to leading as observed in Fig. 3(c).

5. Conclusion

This paper has demonstrated the effect of a GCPV system on the low voltage side of utility power supply. Three important parameters were discussed in detail; voltage, current and power factor; which varied as the solar irradiance changed. Although the power factor is low during low current, it could be penalised by the utility. The utility shall prepare to supply reactive power to the load as the GCPV system only supplies active power to the load. This knowledge could guide towards early preparation to make necessary correction on the load side especially on power factor and voltage at the load terminal.

References

- [1] Asnawi Mohd.Busrah and Vigna Kumaran R., The Impact of Grid Connected Photovoltaic Generation System to Voltage Rise in Low Voltage Network [Online] (2012). Available FTP: <http://www.wseas.us/e-library/conferences/2012/Paris/DEEE/DEEE-04.pdf>
- [2] C. Sirisamphanwong and N. Ketjoy, "Impact of spectral irradiance distribution on the outdoor performance of photovoltaic system under Thai climatic conditions," *Renewable Energy*, 38 (2012) 69-74.
- [3] V. M. Quezada, J. R. Abbad, and T. G. S. Roman, "Assessment of energy distribution losses for increasing penetration of distributed generation," *Power Systems, IEEE Transactions on*, 21 (2006) 533-540.
- [4] B. Kroposki and A. Vaughn, "DG power quality, protection, and reliability case studies report," National Renewable Energy Laboratory, Golden, CO, NREL/SR-560-34635, (2003).
- [5] M. A. Eltawil and Z. Zhao, "Grid-connected photovoltaic power systems: Technical and potential problems - A review," *Renewable and Sustainable Energy Reviews*, 14 (2010) 112-129.
- [6] Y. Ulianov and M. Orozco, "Power quality performance of a grid-tie photovoltaic system in Colombia, in *Transmission and Distribution: Latin America Conference and Exposition (T&D-LA)*," 2012 Sixth IEEE/PES, (2012) 1-7.
- [7] D. Gallo, C. Landi, M. Luiso, and E. Fiorucci, "Analysis of a Photovoltaic System: AC and DC Power Quality," *WSEAS Transactions on Power Systems*, ISSN, 5060 (1790) 45-55.