

Source Contributions of PM-10 Concentrations in the Na Phra Lan Pollution Control Zone, Saraburi, Thailand

Tipawan Phetrawech and Sarawut Thepanondh*

Department of Sanitary Engineering, Faculty of Public Health, Mahidol University, Center of Excellence on Environmental Health and Toxicology, Bangkok, Thailand

Received 19 September 2017; Received in revised form 6 November 2017

Accepted 16 November 2017; Available online 15 December 2017

ABSTRACT

Re-suspended road dust is an important contributor to ambient particulate matter (PM) particularly in an area where fugitive dust is a dominant emission source. This study evaluated PM-10 emissions as fugitive re-suspended dust from the road network in the Na Phra Lan pollution control zone, Saraburi, Thailand. Emissions of road dust were determined by using the analysis of silt loading and physical characteristics of the roads located in the study area. These data were used together with those emissions from point and area sources in the study area to predict the ambient concentrations of PM-10. AERMOD model was applied to predict PM at various receptor points. Source contribution of each emission group to PM-10 ambient concentrations at each receptor were evaluated. Predicted 24 hours PM-10 concentrations at 8 sites from the total of 23 receptors were higher than the PM-10 ambient air quality standard ($> 120 \mu\text{g}/\text{m}^3$). Results revealed that line sources played an important role in contributing to the PM-10 concentrations in this pollution control zone. The highest predicted PM-10 concentration at the receptor was evaluated to have about 71% contribution from mobile source emissions. Therefore, the effort to manage and control emissions of re-suspended road dust could be strengthened for further success of the air pollution control in this area.

Keywords: AERMOD model; Na Phra Lan; PM-10; Road dust

Introduction

Non-exhaust traffic induced particle emissions are known to contribute significantly to the total concentrations of inhalable airborne particulate matter in the size range $<10 \mu\text{m}$ (PM-10) [1]. The evidence on airborne particulate matter (PM) and its public health impact is consistent in showing adverse health effects at exposures that are currently experienced by urban populations in both developed and developing countries [2]. Particulate matter, is a complex mixture of extremely small

particles and liquid droplets. The size of particles is directly linked to their potential for causing health problems. Once inhaled, these particles can affect the heart and lungs and cause serious health effects [3].

In Thailand, PM-10 concentrations monitored in several places had been higher than both of its 24-hour and annual standards (> 120 and $> 50 \mu\text{g}/\text{m}^3$, respectively). Fig. 1 presents the status of PM-10 measured nationwide over the decade (from 2004 – 2013). The worst polluted area from PM-10 of the country is

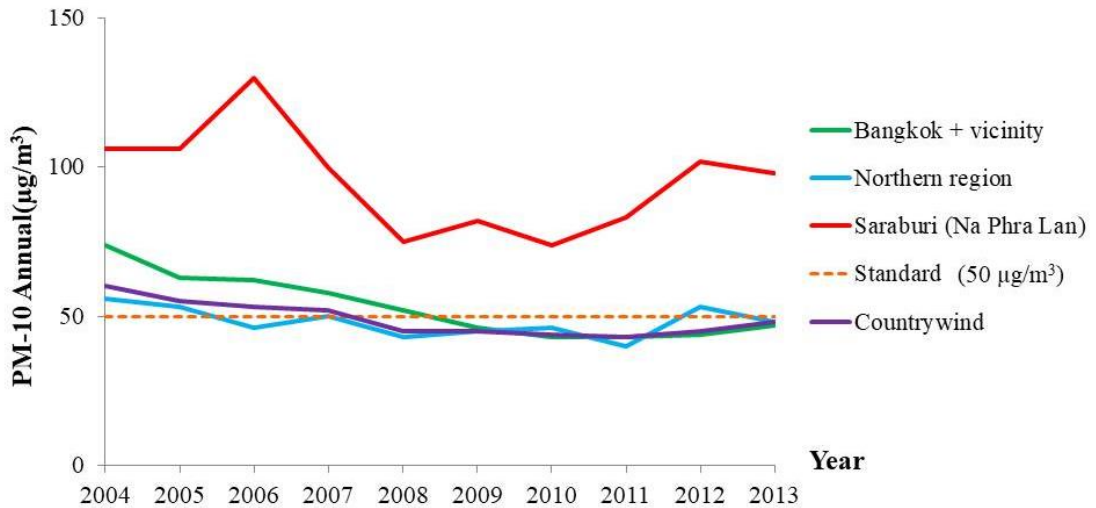

Fig. 1. Spatial and temporal comparison of PM-10 concentrations in Thailand. [1]

at Na Phra Lan Sub-district, Saraburi Province. This area is located in the central region where it is home to the cement manufacturing complex of the country. Due to the problem of very high concentration of PM-10, this area had been designated as “the Pollution Control Zone” by the Thai government since 2004 with an objective to set up specific action plans as well as budgets to combat with this problem.

High concentrations of ambient PM-10 in this area are contributed from activities related to cement manufacturing processes. However, it is suspected that PM-10 measured in the community area are also contributed by the re-suspended road dust. It is well recognized that traffic and road transport are main sources to ambient PM-10 concentrations especially at hot spots in urban environment [4]. Particulate emissions from road transport include tail exhaust, products of wearing processes and re-suspended road dust [5]. Particulates emitted from exhaust of diesel engine are relevant to speed of the vehicle [6] Field measurements in urban areas or megacities shown elevated levels of PM-10 in the vicinity of roads coming from the contribution from re-suspended particles

from paved roads [7]. In urban areas fugitive dust emissions due to vehicles travelling on roads is the most important source of rude particles.

Emissions from road transfer climb from both exhaust and non-exhaust sources. The most important sources of non-exhaust PM are wearing of brake and tyre element of machine vehicles and wearing of the road surface itself. An additional non-exhaust source is the suspension or re-suspension of previously placed material from the road surface road dust by vehicle induced confusion, tyre crop and the turbulent achievement of the wind. In addition to direct tailpipe emissions of particulates, mobile sources are also accountable for fugitive dusts such as those re-suspended from road.

This study assessed PM-10 emissions of re-suspended dust from the road network in the Na Phra Lan Pollution Control Zone. Emissions of road dust are determined by using the analysis of silt loading and physical characteristics of the unpaved and pave roads located in the study domain. Then emission fraction of PM-10 re-suspended from road are developed and further be used as input data for

interpretation of their ambient concentration using the air pollution dispersion model. Predicted PM-10 concentrations at each receptor point were evaluated for its sources contribution in order to reveal the influence of emission sources to the ambient PM-10 concentrations in this pollution control zone.

Materials and Methods

In this study, amount of PM-10 emitted from re-suspension of road dust in the Na Phra Lan Pollution Control Zone was estimated. The study domain covered area of 3 x 3 km² was centered at the Na Phra Lan ambient air monitoring station of the Pollution Control Department (reference point). There were 5 major roads within the study domain as illustrated in Fig. 2. Information on the characteristics of each road located within the study domain is summarized in Table 1.

Sampling locations in each road were designed according to their length and distant between road conjunctions or intersections (road segments). Criteria of selection of sampling points are presented in Fig. 3. Totally, there were 21 dust sampling locations in these roads. The sampling points were designed following the US.EPA AP-42 document in order to assure their representativeness as illustrated in Fig.3. For a road segment having the distance between each intersection of more than 2.4

km, a composite sample was created from a minimum of 3 incremental samples. The first increment was collected at a random location within the first 800 m, with additional increments taken from each remaining 800 m of the road. For a shorter road segment (<2.4 km), an acceptable method for selecting sites for the increments is based on drawing 3 random numbers between zero and the length [8]. The road dusts were collected directly from road pavement by manual sweeping of the dust during the dry season (March 2016). The dust sample plot used in this study was patterned after the ASTM-C-136 method. It had been designed with a rectangular-shaped leading edge. The sample plot was made of Acrylic plastic and had the size of 0.3 x 0.3 m² with 0.15 m wing. At least 3-5 plots were sampled at the same sampling location. Collected samples at each sampling locations were then put in the same plastic bag (composite sampling).

Emission rates of PM-10 emitted from re-suspended road dust was then calculated following the US.EPA AP-42 (section 13.2.1 and 13.2.2). The data collected on-site included amount of dust in the study plot, and diurnal profile of number and type of vehicles traveling on the roads (on an hourly basis) within the study domain.

Table 1. Characteristic of the roads under investigation.

Road	Length (km)	No. of lanes	Total daily traffic volume	% of truck
(1) Phaholyothin	6.47	8	36900	17.11
(2) Saraburi-Lomsak	4.78	6	15858	26.14
(3) Kung Khao Keaw	0.86	2	1918	47.03
(4) 3385	3.42	4	4287	5.27
(5) 3034	3.01	4	10674	38.75



Fig. 2. Major roads within the study domain.

Note; 1: Phaholyothin Rd., 2: Saraburi – Lomsak Rd., 3: Road No.3034, 4: Road No.3385, 5: Kung Khao Keaw Rd., and Reference point is the Na Phra Lan ambient air monitoring station of the Pollution Control Department.

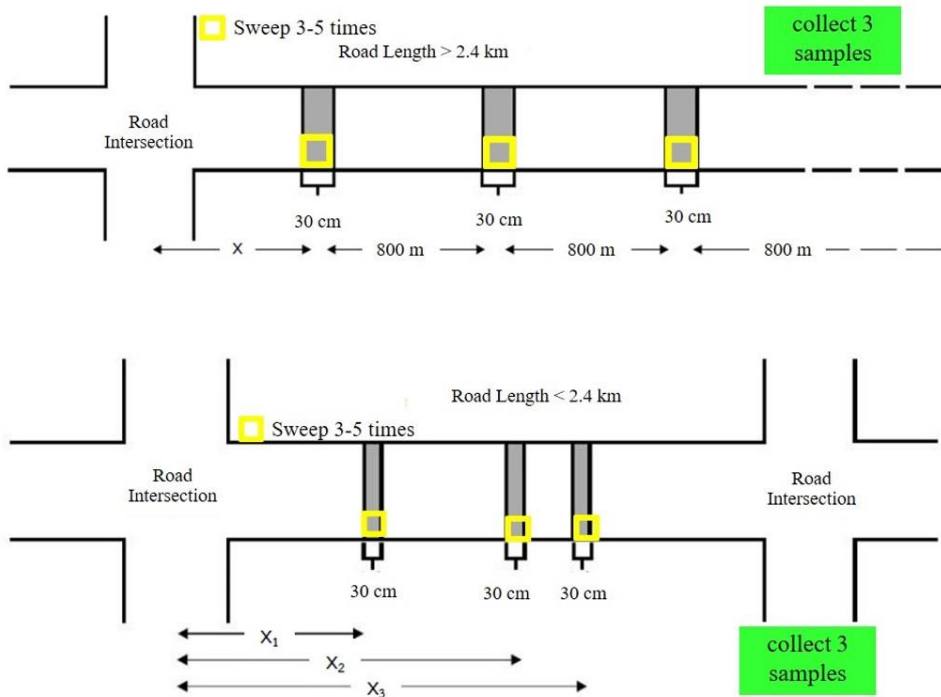

Fig. 3. Locations of sampling points. [8]

Silt Analysis

Dust emissions from paved and unpaved roads have been found to vary with the “silt loading” present on the road surface as well as the average weight of vehicles traveling the road. The term silt loading refers to the mass of silt-size material (equal to or less than 75 µm in physical diameter) per unit area of the travel surface. The total road surface dust loading consists of loose material that can be collected by broom sweeping of the traveled portion of the road. The silt fraction is determined by measuring the proportion of the loose dry surface dust that passes through a 200-mesh screen using the ASTM-C-136 method. Silt loading is the product of the silt fraction and the total loading.

Several open dust emission factors have been found to be correlated with the silt content (< 200 mesh) of the material being disturbed. The basic procedure for silt content determination is mechanical, dry sieving. For sources other than paved roads, the same sample which was oven-dried to determine moisture content is then mechanically sieved. The broom swept particles are weighed in a container, which was tarred before sample collection. After weighing the sample to calculate total surface dust loading on the traveled lanes, the broom swept particles were combined as a composite sample [8]. Samples were dried in an oven at 130°C to remove moisture and were equilibrated in the desiccator prior be sieved.

Collected dust were then sieved using mechanical shaker (model: Retsch AS200) through the 200 mesh screen (75 µm) for 10 minutes. The total net weight and net weight of particle < 200 mesh were used to calculate percent of silt using equation (1). Results of percent of silt measured from each road are as presented in Table 2.

$$\%Silt = \frac{NetWeight < 200\ mesh}{Total\ Net\ Weight} \times 100 \quad (1)$$

Table 2. Percent of silt on each road

Roads	Silt (g/m ²)	% Silt
Phaholyothin (1)	5.38	2.79
Saraburi-Lomsuk (2)	0.78	1.80
Kung Khao Kaew(3)	38.11	3.49
3385(4)	1.22	1.12
3034(5)	1.33	1.92

PM-10 Emissions

Amount of PM-10 emitted from re-suspended road dust were calculated by equation 2.

$$EF = k \times sL^{0.91} \times W^{1.02} \quad (2)$$

Where; EF is particulate emission factor (having units matching the units of k), k is particle size multiplier for particle size range and units of interest (0.62 g/VKT for PM-10), sL is road surface silt loading (grams per square meter; g/m²), and W is average weight (tons) of the vehicles traveling the road. VKT is vehicle kilometer travel.

Predicted of PM-10 ambient concentration

Emission data from this analysis were then used as input data for the AERMOD dispersion model (version 9.1.0). AERMOD is a steady state Gaussian plume model developed under support of the American Meteorological Society (AMS) and the U.S. Environmental Protection Agency (EPA) [9], [10], [11]. It is suitable for estimating impacts from short-range transport for distances less than 50 km. It has been widely used for environmental impact assessment purpose [12], [13], [14].

The AERMOD modeling system is composed of three modular components: AERMOD mapping program (AERMAP), AERMOD meteorological preprocessor (AERMET), and AERMOD, the control module and modeling preprocessor. AERMOD is used mostly for modeling the

dispersion of point source emissions in rural and urban areas accounting various inbuilt option for flat and complex terrain, surface and elevated releases [15],[16]. The meteorological pre-processor AERMET calculates the PBL (Planetary boundary layer) parameters and surface heat flux using surface characteristics and meteorological observations (wind speed, wind direction, temperature and cloud cover). An interface of AERMOD is used to pass these parameters in order to calculate vertical profiles of wind speed, lateral and vertical turbulent fluctuations, and the potential temperature gradient. The information of various parameterizations in the model was given by [17].

The modeling domain were 3.5 x 3.5 km² centered at 701572, 1624418. The terrain characteristics of the study area used in the model were derived from the SRTM3 database (90 m resolution). Local

meteorological data were used as the surface data while the upper air data were simulated using the MM5 model. Numbers of grid points were 4624 grids with the finest grid spacing of 100 m.

Results and Discussion

In order to evaluate spatial distribution of PM-10 concentration in this Pollution Control Zone, emission data from stacks of cement industry and rock piles of grist mills located in the study domain were included in the analysis. Emission of these sources were derived directly from the factories (for stack) and from emission factor of US.EPA. AP-42 calculation (for rock piles).

The emission rate of PM-10 on each source were used as input data in the model simulation. Results were illustrated in Figure 4-7.

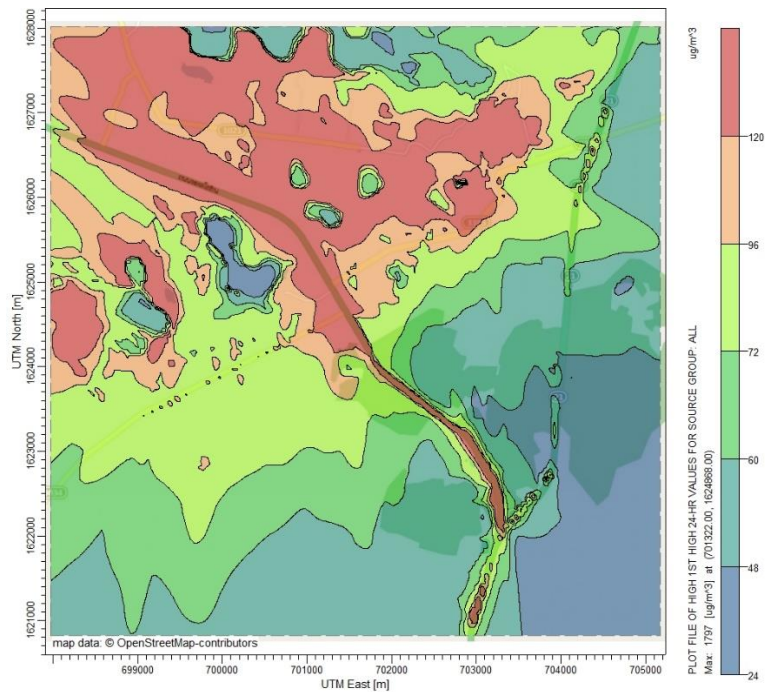

Fig.4. Spatial distribution of PM-10 concentrations from all sources.

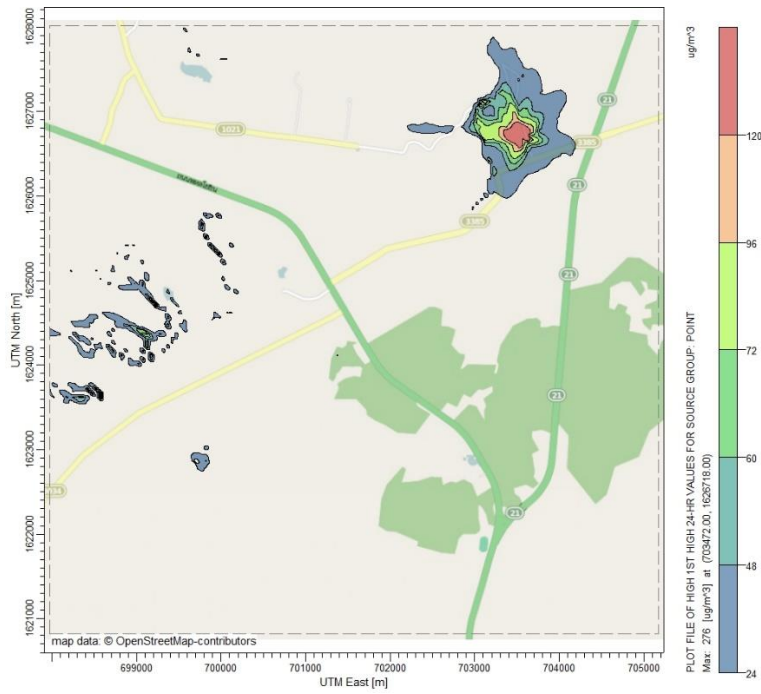

Fig.5. Spatial distribution of PM-10 concentrations from point sources.

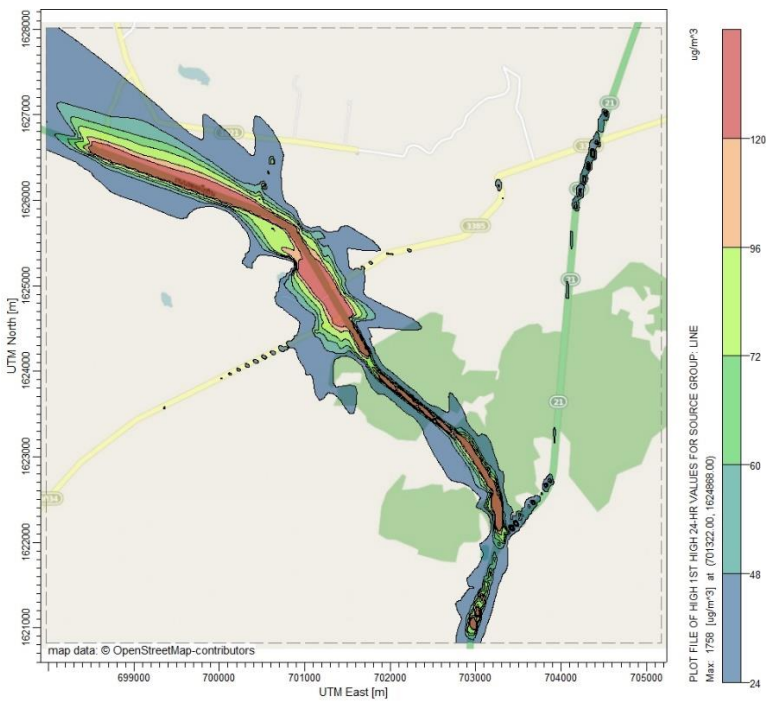

Fig.6. Spatial distribution of PM-10 concentrations from line sources.

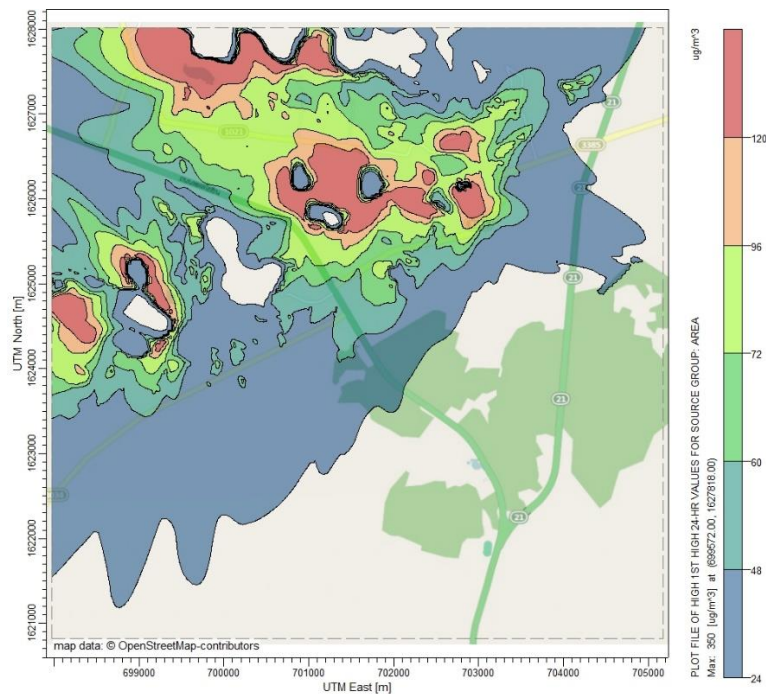

Fig.7. Spatial distribution of PM-10 concentrations from area sources.

The areas predicted to have their daily PM-10 concentration higher than the ambient air quality standard ($> 120 \mu\text{g}/\text{m}^3$) are illustrated using red color. Generally, it is found that the major emission source contributed to PM-10 concentrations in this pollution control zone is from the area source as shown in Figure 7. However, the affected areas from this emission source are mainly within the factory and mining areas. Further analysis of emission source contributions to the PM-10 concentrations were carried out for each specific receptor in order to assist in the evaluation of extent and magnitude of environmental impact to the population living in this area. Twenty three sensitive areas such as school, local government office, temple and community located within the study domain were selected as receptors to serve this purpose. Spatial distribution of receptor is illustrated in Fig. 8. Predicted concentration at each receptor and percentage of emission source contribution to the PM-10 ambient concentration are as presented in Table 3.

Among 23 receptors, there were 8 receptors having predicted daily PM-10 concentrations higher than its ambient air quality standard. Mostly of them were mainly affected by the line source emissions due to their adjacent to the roads. The highest PM-10 concentration of $256 \mu\text{g}/\text{m}^3$ was predicted at Chum Chon Ban Khao Tai (receptor No.13). About 70% of the predicted concentration was analyzed to be contributed from the line source emissions. There were only 2 receptors, namely Khung Khao Khiao Temple and Ban Khung Khao Khiao School which the predicted PM-10 concentrations were mainly contributed by area sources since they are located in the mining areas. It should be noted that the analysis of emission source contribution to the PM-10 concentration at the location where the ambient air quality station has been placed in the Na Phra Lan pollution control zone (receptor No.1) was evaluated to be mainly influenced by line source emissions (71% contribution). Therefore, the effort to control the re-suspended road

dust should be given priority as well as setting up more stringent mitigation measures to control this emission source particularly when the measured data from

this ambient air quality station is used to evaluate the success of PM-10 control in this area.

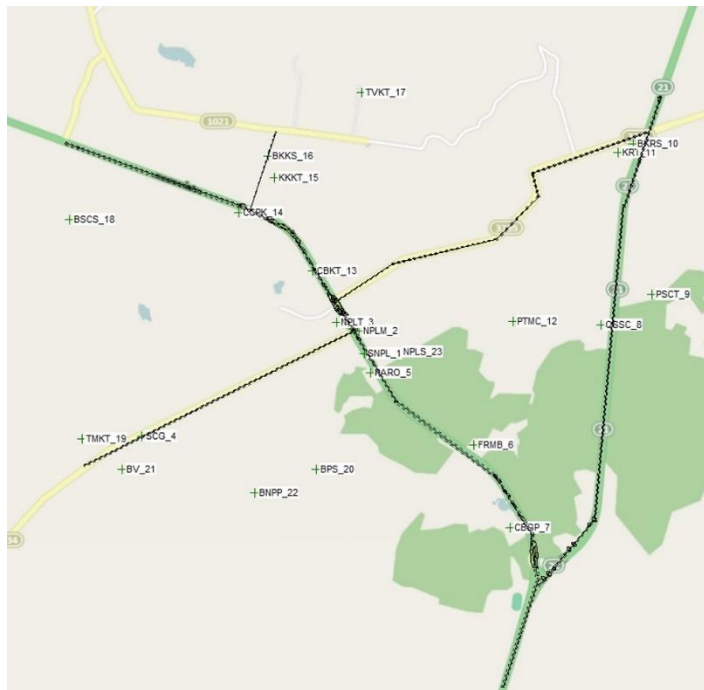

Fig.8. Location of receptors for source contribution analysis.

Table 3. Predicted PM-10 and analysis of source contribution at each receptor.

Receptor	PM-10 ($\mu\text{g}/\text{m}^3$) (24 hr average)*	% of emission source contribution to PM-10 concentration		
		Point source	Line source	Area source
1. Air quality station in Na Phra Lan	182	3	130	49
2. Na Phra Lan Municipality	212	3	153	56
3. Na Phra Lan Temple	230	2	178	50
4. Siam Cement Group	82	9	28	45
5. Protected Areas Regional Office	143	3	95	45
6. Forest Resource Management Bureau 5 th	47	4	28	15
7. Central Botanical Garden (Pukae)	61	2	49	10
8. Queen Sirikit Sericulture Center	31	4	10	17
9. Pa Somphon Chai Temple	35	4	7	24
10. Bankhaoruak School	57	21	13	23
11. Khaoruak Temple	54	23	6	25

Table 3. Predicted PM-10 and analysis of source contribution at each receptor. (Continue)

Receptor	PM-10 ($\mu\text{g}/\text{m}^3$) (24 hr average)*	% of emission source contribution to PM-10 concentration		
		Point source	Line source	Area source
12. Phra Trairat Meditation Center	33	7	7	19
13. Chum Chon Ban Khao Tai	256	3	179	74
14. Chum Chon Chalermprakiet	150	4	78	68
15. Khung Khao Khiao Temple	174	5	34	135
16. Ban Khung Khao Khiao School	177	5	72	100
17. Tham Vimarn Kaeo Temple	86	10	8	68
18. Bansubchaom School	76	18	14	44
19. Tham Mongkut Temple	53	4	6	43
20. Ban Promsuk	48	4	16	28
21. Ban Vung	52	5	7	40
22. Ban Nong Pah Pong	48	7	10	31
23. Naphralan School	69	4	18	47

Remark: * *italic value* denotes that the concentrations exceed the Thai ambient PM-10 24-hours standard of 120 $\mu\text{g}/\text{m}^3$

Conclusion

Emission rates of PM-10 released from re-suspended road dust were evaluated for an area designated as Pollution Control Zone in Thailand. Results revealed the diurnal profile of amount of particulate emissions with respect to number of total vehicle and contribution of heavy duty truck travelling in this area. These data were used together with those emissions from point and area sources located in the study domain to simulate for PM-10 ambient concentrations by using the AERMOD model. Predicted concentrations of PM-10 at each receptor points were evaluated and were further analyzed for their emission source contributions. Data revealed that almost receptors were affected from re-suspended road dust while the extent of point and areas sources were dominated at some receptor points where there were located adjacent to the source. Finding from this study reveals that beside the effort to control PM-10 emitted from the industrial sources, there also the need to properly

manage and control emissions of re-suspended road dust for an effective diminishing of PM-10 concentrations in this pollution control zone.

Acknowledgements

The authors sincerely thanks the Pollution Control Department, the Siam Cement Public Company Limited, and Na Phra Lan Sub-district Municipality for providing input data used in this study. This study was partially supported for publication by the China Medical Board (CMB) and Center of Excellence on Environmental Health and Toxicology (EHT), Faculty of Public Health, Mahidol University, Thailand.

References

- [1] Norman B, Sundvor IC, Denby BR, Johansson C, Gustafsson M, Blomqvist G, et al. Modelling road dust emission abatement measures using the NORTRIP model: Vehicle speed and studded tyre

- reduction. *Atmos Environ* 2016;134:96-108.
- [2] World Health Organization. WHO Air quality guidelines for particulate matter, ozone, nitrogen dioxide and sulfur dioxide Global update 2005 Summary of risk assessment. 2006:9.
- [3] Environmental Protection Agency. Particulate matter (PM) [Internet]. Washington DC; 2016 [cited 2016 May 25]. Available from: <https://www3.epa.gov/pm>.
- [4] Ketzel M, Omstedt G, Johansson C, Ingo Du` RI, Pohjola M, Oettl D, et al. Estimation and validation of PM-2.5/PM-10 exhaust and non-exhaust emission factors for practical street pollution modelling. *Atmos Environ* 2007;41:9370-85.
- [5] Cheng YH, Li YS. Influences of traffic emissions and meteorological conditions on ambient PM-10 and PM-2.5 levels at a highway toll station. *Aerosol Air Qual Res* 2010;10:456-62.
- [6] Outapa P, Kondo A, Thepanondh S. Effect of speed on emissions of air pollutants in urban environment: case study of truck emissions. *Int J GEOMATE* 2016;11:2200-7.
- [7] Pay MT, Guerrero PJ, Baldasano JM. Implementation of resuspension from paved roads for the improvement of CALIOPE air quality system in Spain. *Atmos Environ* 2011;45:802-7.
- [8] Measurement Policy Group Office of Air Quality Planning and Standards U.S. Environmental Protection Agency. Emission Factor Documentation for AP-42. Washington DC: U.S. EPA; January 2011.
- [9] Perry SG, Cimorelli AJ, Paine RJ, Brode RW, Weil JC, Venkatram A, et al. AERMOD: A dispersion model for industrial source applications. Part II: Model performance against 17 field study databases. *J Appl Meteorol* 2005:694-708.
- [10] U.S. Environmental Protection Agency. User's Guide for the AMS/EPA Regulatory Model-AERMOD. EPA-454/B-03-001 [Internet]. Washington DC; 2004 [cited 2016 Jun 30]. Available from: <http://www.epa.gov/scram001/7thconf/aermod/aermodugb.pdf>.
- [11] Chusai C, Manomaiphiboon K, Saiyasitpanich P, Thepanondh S. NO₂ and SO₂ dispersion modeling and relative roles of emission sources over Map Ta Phut industrial area, Thailand. *J Air Waste Manage* 2012;62(8):932-45.
- [12] Silverman KC, Tell JG, Sargent EV, Qiu Z. Comparison of the industrial source complex and AERMOD dispersion models: case study for human health risk assessment. *J Air Waste Manage* 2007;57(12):1439-46.
- [13] Huertas JI, Huertas ME, Izquierdo S, González ED. Air quality impact assessment of multiple open pit coal mines in northern Columbia. *J Environ Manage* 2012;93(1):121-9.
- [14] Khamyingkert L, Thepanondh S. Analysis of industrial source contribution to ambient air concentration using AERMOD dispersion model. *Environment Asia* 2016;9(1):28-36.
- [15] Pandey G, Sharan M. Simulation of plume dispersion of multiple releases in Fusion Field Trial-07 experiment. *Atmos Environ* 2015;122:672-85.
- [16] Jittra N, Pinthong N, Thepanondh S. Performance evaluation of AERMOD and CALPUFF air dispersion models in industrial complex area. *Air, Soil and Water Research* 2015;8:87-95.
- [17] Cimorelli AJ, Perry SG, Venkatram A, Weil JC, Paine RJ, Wilson RB, et al. AERMOD: a dispersion model for industrial source applications. Part I: general model formulation and boundary layer characterization. *J Appl Meteorol* 2005;44:682-93.